

Price \$39.95

C.B. TUNE-UP MANUAL

MASTER EDITION

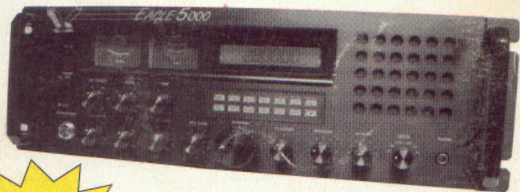

Volume 7

Covers standard radio tune-up information
Channel modifications
Repair tips

* All Rights Reserved

TABLE of CONTENTS

	<u>PAGE</u>		<u>PAGE</u>
Radio Tune-Up Section.....	4, 5	GALAXY DX77HML SUPER-TALK Installation Instructions.....	28
TUNE-UP & PEAKING INFO for the Following:			
COBRA 19DX LTD (<i>Limited Edition</i>).....	4	GALAXY DX88HL SUPER-TALK Installation Instructions.....	28
COBRA 93LTD WX.....	4	COBRA 148F-GTL (<i>New Malaysia Model</i>) Clarifier Slide Modification.....	29
COBRA 148F GTL.....	4	Super-Slide Clarifier Modification.....	30
DIRLAND SS-3000B.....	4	Switch Channel Conversion.....	31
EAGLE 2000.....	4	Switch Channel Conversion Freq. Chart.....	32
EAGLE 5000.....	4	Rotary Channel Conversion.....	33
GALAXY DX 99V (<i>EPT 360014B Board</i>).....	5	Rotary Switch Channel Conv. Freq. Chart.....	34
GALAXY Mirage 88 (<i>EPT 360014B Board</i>).....	5	UNIDEN GRANT XL (<i>Update</i>) Clarifier Slide Modification Update.....	35
MAXON MCB-60.....	5	Super-Slide Clarifier Modification Update.....	36
MIDLAND 77-104XL.....	5	EPTOSSB50B ECHOBOARD (<i>Connex</i>) Installation Instructions.....	37
MIDLAND 75-800.....	5	RADIO TRANSMIT MODIFICATION SECTION	
RANGER RCI-2980.....	5	COBRA 25LTD WX Classic.....	38
RANGER RCI-2990.....	5	COBRA 29LTD WX Classic.....	38
SUPERSTAR 3900G.....	5	UNIDEN PC 66XL.....	38
UNIDEN HR-2510 (<i>New Release</i>).....	5	UNIDEN PC 76XL.....	38
UNIDEN PRO501XL.....	5	UNIDEN PC 76XLW.....	38
PC76XLW.....	5	UNIDEN PC 122XL.....	38
Correction to Volume II Page 11.....			
6			
EAGLE 2000			
Channel Conversion.....	7	VARIABLE ALIGNMENT SECTION	
Channel Chart.....	10	COBRA 19DX LTD.....	39
EAGLE 5000			
Spec Sheet Info.....	11	COBRA 93LTD WX.....	39
Channel Conversion.....	12	COBRA 148F GTL.....	39
RANGER RCI-2980			
Channel Conversion.....	13	DIRLAND SS-3000B.....	39
Channel Chart.....	16	EAGLE 2000 (<i>EPT 360014B Board</i>).....	39
RANGER RCI-2990			
Channel Conversion.....	17	EAGLE 5000 (<i>EPT 295013Z Board</i>).....	39
GALAXY DX33HML			
Channel Conversion.....	18	GALAXY DX 99V (<i>EPT 360014B Board</i>).....	40
Channel Chart.....	19	GALAXY MIRAGE 88 (<i>EPT 360014B Board</i>).....	40
GALAXY DX44V			
Channel Conversion.....	20	MAXON MCB-60.....	40
Channel Chart.....	22	MIDLAND 77-104XL.....	40
GALAXY DX55V			
Channel Conversion.....	23	RCI-2980 (<i>EPT 360014B Board</i>).....	40
Channel Chart.....	24	RCI-2990 (<i>EPT 295013Z Board</i>).....	40
GALAXY DX99V			
Channel Conversion.....	25	UNIDEN PC 76XLW.....	41
Channel Chart.....	27	UNIDEN PC 122XL.....	41
		UNIDEN PC 501XL.....	41
		MIKE WIRING SECTION.....	41
		MIKE WIRING CHARTS.....	42, 53
		INDEX.....	55



©1995

All Domestic and Foreign Rights Reserved

101295400AM

©1995 Thomas Publishing (217) 466-4210

CB TUNE-UP MANUAL Master Edition Vol. 7

CB. TUNE-UP MANUAL MASTER EDITION

VOLUME 7

©1995 ALL RIGHTS RESERVED

THOMAS PUBLISHING

FOREWORD

Many new radio models have been introduced since Volume 6 was released. These new models have excellent capabilities and features and incorporate much of the new integrated circuit technology now available.

One of the latest new radios just introduced, is the *EAGLE 5000*. This new model has features that you'll find on only the top of the line models. Other new models include the *EAGLE 2000*, *RANGER® RCI-2980*, *Ranger RCI-2990*, as well as models from *COBRA®*, *UNIDEN®*, and many *GALAXY Export Models*. Many of these models are included and updated in this edition.

INTRODUCTION

Improving CB. performance is often attempted by many without knowing which adjustments to use, or modifications to make. Even more frustrating is trying to remember and/or to compile this information for future use. As new radios arrive on the market it is almost impossible to acquire good easy to understand

technical and modification Info. It is our goal to supply you with good useful information in an *easy to understand and use MANUAL FORMAT*. We feel that it is very important to supply information that will be useful and profitable for you, the technician.

Included in this volume is a complete *Index* listing covering *CB TUNE-UP MANUALS Volume 1 through Volume 7*. This should be a great time saver for any future reference.

THOMAS PUBLISHING, 128 EAST WOOD PARIS, IL 61944

© 1995 (All Domestic and Foreign Rights Reserved)

This manual is printed with Blue Ink.

HOW TO USE TUNE-UP INFORMATION

In COLUMN 1 you will find the MODEL NUMBER of each radio, COLUMN 2 provides MODULATION information, COLUMN 3 provides AM POWER ADJUSTMENTS, and COLUMN 4 lists S.S.B. ADJUSTMENTS if applicable. On some S.S.B. models we have shown 2 adjustments. The first will be for S.S.B. modulation and the second is for the S.S.B. power (ALC). If only one adjustment is shown in the SSB column then it will be for S.S.B. power (ALC).

MANUFACTURER NAME			
MODEL	MODULATION	AM POWER	SSB POWER
MCB-5000 ¹	R268 or Cut D207 or Rem.C273	L202,L204	RV8,RV5
See footnote for more specific information.	Adjust R268 for modulation or cut one end of D207 or remove C273 from the circuit.	Adjust L202 & L204 for Am Power .	Adjust RV8 for SSB modulation & RV5 for SSB power.

Some of the Power Adjustments listed are expandable type coils. These coils can be adjusted by either spreading the coils apart or by moving the coils closer together. These coils can be modified by removing 1 turn in order to allow you to move them closer together if needed, and thus increase tuning range.

COBRA RADIOS			
MODEL	MODULATION	AM POWER	SSB POWER
I9DX LTD	Adjust RV2 or cut one end of D8	L201	
93 LTD WX	Adjust VR3 or remove C64 ¹	L2	
I48F GTL	Adjust V7 or Cut R131	VR10	VR11

¹ Removing C64 may cause feedback in some 93 LTD WX models. Normally adjusting VR3 will supply good modulation.

DIRLAND RADIOS			
MODEL	MODULATION	AM POWER	SSB POWER
SS-3000 B ¹	Locate and Remove TR32	VR13 (Hi Pwr)VR16 (Lo Pwr)	

¹ Model using the EPT 120112Z Circuit Board.

EAGLE RADIOS			
MODEL	MODULATION	AM POWER	SSB POWER
Eagle 2000 ¹	Adjust VR14 or cut one end of R249	VR13 (Hi Pwr)VR16 (Lo Pwr)	VR12
Eagle 5000 ²	Adjust VR14	VR13 (Hi Pwr)VR16 (Lo Pwr)	VR12

¹ Model using the EPT 360014B Circuit Board.

² Model using the EPT 295013Z Circuit Board

GALAXY RADIOS

MODEL	MODULATION	AM POWER	SSB POWER
DX-99V ¹	Adjust VR14 or remove TR53	VR13 (Hi Pwr)/VR16 (Lo Pwr)	VR12
MIRAGE 88 ¹	Adjust VR14 or remove TR53	VR13 (Hi Pwr)/VR16 (Lo Pwr)	VR12

¹ Model using the EPT 360014B Circuit Board.

MAXON® RADIOS

MODEL	MODULATION	AM POWER	SSB POWER
MCB-60	Adjust RV201 or remove C215	L304, L305, L306	

MIDLAND® RADIOS

MODEL	MODULATION	AM POWER	SSB POWER
77-104XL ¹	Adjust VR4 or cut one end of D13	L3, L6, L7	
75-800 (Handheld)	Adjust RV3	N/A	

¹ REV A 090-681201-00 Board

RANGER RADIOS

MODEL	MODULATION	AM POWER	SSB POWER
RCI-2980	Adjust VR14 or Cut one end of R249	VR13 (Hi Pwr)/VR16 (Lo Pwr)	VR12
RCI-2990	Adjust VR14	VR13 (Hi Pwr)/VR16 (Lo Pwr)	VR12

SUPER STAR RADIOS

MODEL	MODULATION	AM POWER	SSB POWER
3900G	VR14 or Cut one end of R249	VR13	VR12

UNIDEN RADIOS

MODEL	MODULATION	AM POWER	SSB POWER
HR2510 (New Release)	Adjust VR114	VR103	VR104
PRO501XL ¹	Cut one end of D2	L101, L102	
PC76XLW	Adjust VR4 or cut one end of D11	L12, L13, L14	

¹ New model from Uniden that utilizes a 6 pin phone type mike plug.
Color codes for the stock mike wires are as follows: Red = Audio, Black = Shield, Yellow = Receive, Green = Transmit

Notes

CHANNEL CONVERSIONS

Correction to Volume II page 11
Revised Edition

Due to the many requests for Channel Modification information we have included the following chip conversions. In order to keep our manual simple and easy to understand we also decided to show most of these as individual modifications by channel group.

This will allow you to add channels by group or mix & match at will. As always this is supplied for informational purposes only.

PLL 02A LOW CHANNEL CONVERSION (#1)

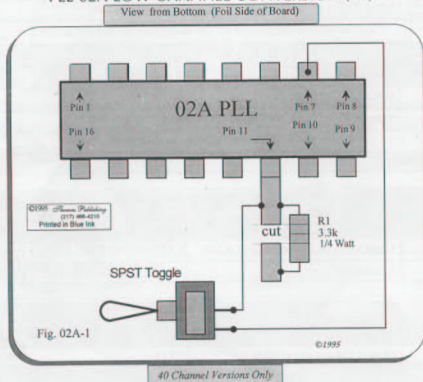

Instructions

1. Locate Pin 11 and Isolate it by cutting the foil which connects it to the channel selector. Install a 3.3K 1/4 watt resistor across this cut.
2. Using a SPST mini toggle switch connect wires from the switch as shown in the above diagram. This will yield low channels starting at 26.805 and ending at 26.905 with some skips in between. This modification picks up some channels skipped by Modification #4.

LOW CHANNEL FREQUENCY CHART

1 = 26.805	4 = 26.845	7 = 26.875
2 = 26.815	5 = 26.855	8 = 26.895
3 = 26.825	6 = 26.865	9 = 26.905

Channel Conversion Instructions

Step 1.) Turn the unit upside down with the front towards you and remove the eight screws holding the bottom cover. Set the bottom cover aside.

Step 2.) Next locate the wire (normally black) soldered to the circuit board as shown in Fig. 1. Carefully unsolder this wire and remove.

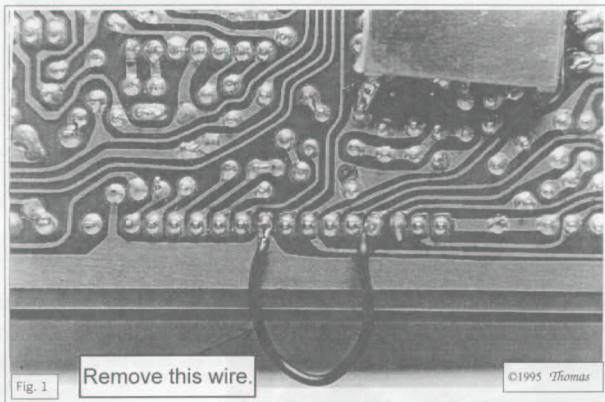

Step 3.) Before proceeding, be sure that you have no solder touching on any of the pins after removing this wire. Proceed to step 4 on the next page.

Step 4.)

Now locate the solder connection as shown in Fig.2. Using solder wick, carefully desolder this connection, separating these two solder joints. Be sure that you unsolder only this connection.

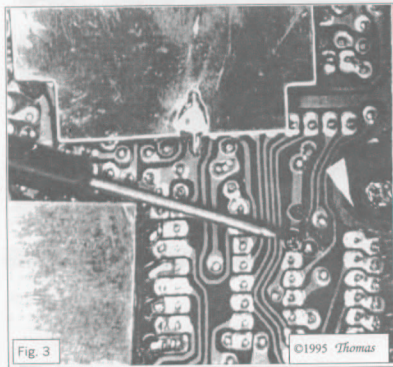
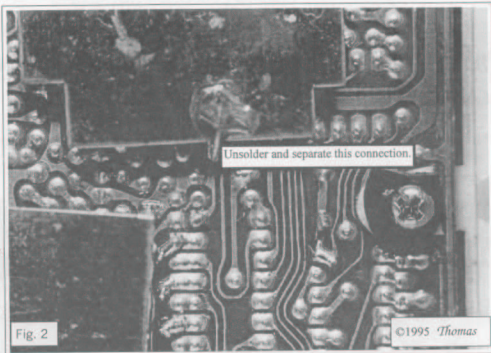

Step 5.)

After separating this connection, carefully check for any shorts or solder bridges that may have occurred while performing Step 4. The connection should now appear as shown in Fig. 3. Once you are sure that everything is ok, proceed to Step 6 on the following page.

EAGLE 2000
Channel Conversion

Step 6.) The next step is to locate the purple wire that was left unsoldered or cut from the band selector switch at the factory. Fig. 4 below shows the band selector switch with the small stub connected to it.

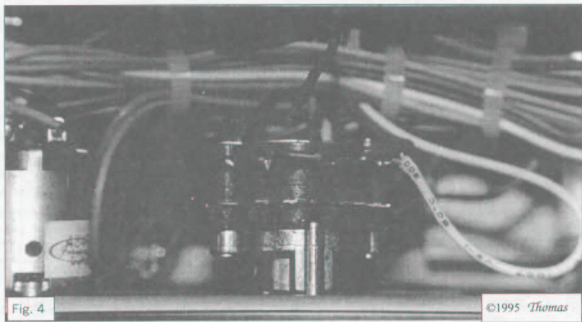

Step 7.) Once you have located this wire carefully solder it to the band selector switch as shown in Fig. 5. Again take care and do not use excessive heat when resoldering this connection.

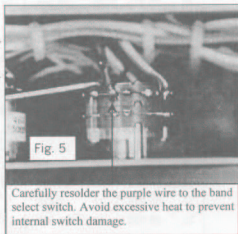

Step 8.) At this point your radio will now cover from 25.615 to 28.305 MHz as shown on the frequency chart for the Eagle 2000 on the following page.

EAGLE 2000 FREQUENCY CHANNEL CHART

A		B		C		D		E		F	
Channel	Frequency	Channel	Frequency	Channel	Frequency	Channel	Frequency	Channel	Frequency	Channel	Frequency
1	25.615	1	26.065	1	26.515	1	26.965	1	27.415	1	27.865
2	25.625	2	26.075	2	26.525	2	26.975	2	27.425	2	27.875
3	25.635	3	26.085	3	26.535	3	26.985	3	27.435	3	27.885
4	25.655	4	26.105	4	26.555	4	27.005	4	27.455	4	27.905
5	25.665	5	26.115	5	26.565	5	27.015	5	27.465	5	27.915
6	25.675	6	26.125	6	26.575	6	27.025	6	26.475	6	27.925
7	25.685	7	26.135	7	26.585	7	27.035	7	27.485	7	27.935
8	25.705	8	26.155	8	26.605	8	27.055	8	27.505	8	27.955
9	25.715	9	26.165	9	26.615	9	27.065	9	27.515	9	27.965
10	25.725	10	26.175	10	26.625	10	27.075	10	27.525	10	27.975
11	25.735	11	26.185	11	26.635	11	27.085	11	27.535	11	27.985
12	25.755	12	26.205	12	26.655	12	27.105	12	27.555	12	28.005
13	25.765	13	26.215	13	26.665	13	27.115	13	27.565	13	28.015
14	25.775	14	26.225	14	26.675	14	27.125	14	27.575	14	28.015
15	25.785	15	26.235	15	26.685	15	27.135	15	27.585	15	28.025
16	25.805	16	26.255	16	26.705	16	27.155	16	27.605	16	28.035
17	25.815	17	26.265	17	26.715	17	27.165	17	27.615	17	28.055
18	25.825	18	26.275	18	26.725	18	27.175	18	27.625	18	28.065
19	25.835	19	26.285	19	26.735	19	27.185	19	27.635	19	28.075
20	25.855	20	26.305	20	26.755	20	27.205	20	27.655	20	28.085
21	25.865	21	26.315	21	26.765	21	27.215	21	27.665	21	28.105
22	25.875	22	26.325	22	26.775	22	27.225	22	27.675	22	28.115
23	25.905	23	26.355	23	26.805	23	27.255	23	27.705	23	28.155
24	25.885	24	26.335	24	26.785	24	27.235	24	27.685	24	28.135
25	25.895	25	26.345	25	26.795	25	27.245	25	27.695	25	28.145
26	25.915	26	26.365	26	26.815	26	27.265	26	27.715	26	28.165
27	25.925	27	26.375	27	26.825	27	27.275	27	27.725	27	28.175
28	25.935	28	26.385	28	26.835	28	27.285	28	27.735	28	28.185
29	25.945	29	26.395	29	26.845	29	27.295	29	27.745	29	28.195
30	25.955	30	26.405	30	26.855	30	27.305	30	27.755	30	28.205
31	25.965	31	26.415	31	26.865	31	27.315	31	27.765	31	28.215
32	25.975	32	26.425	32	26.875	32	27.325	32	27.775	32	28.225
33	25.985	33	26.435	33	26.885	33	27.335	33	27.785	33	28.235
34	25.995	34	26.445	34	26.895	34	27.345	34	27.795	34	28.245
35	26.005	35	26.455	35	26.905	35	27.355	35	27.805	35	28.255
36	26.015	36	26.465	36	26.915	36	27.365	36	27.815	36	28.265
37	26.025	37	26.475	37	26.925	37	27.375	37	27.825	37	28.275
38	26.035	38	26.485	38	26.935	38	27.385	38	27.835	38	28.285
39	26.045	39	26.495	39	26.945	39	27.395	39	27.845	39	28.295
40	26.055	40	26.505	40	26.955	40	27.405	40	27.855	40	28.305

EAGLE 5000

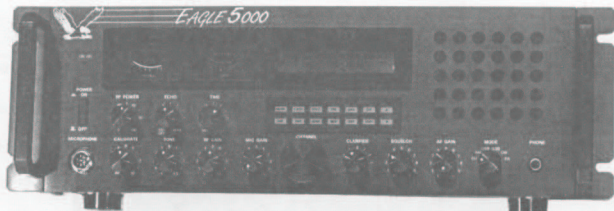

Specifications

<i>General</i>		<i>Receiver</i>	
Modulation Modes	CW, FM, AM, USB, LSB, PA	AM Sensitivity	1 μ V for 10 dB S/N
Frequency Range	28.000 - 29.699 MHz (Factory)	FM Sensitivity	1 μ V for 20 dB S/N
Frequency Control	Phase-Locked synthesizer	SSB Sensitivity	0.2 μ V for 10 dB S/N
Frequency Tolerance	\pm 0.005 %	AM/FM Selectivity	5 dB at 4 kHz, 50 dB at 10 kHz
Frequency Stability	\pm 0.003 %	SSB Selectivity	5 dB at 2 kHz
Operating Temperature Range	-30 °C to +50 °C	Image Rejection	More than 50 dB
Microphone	Plug-in [6-pin], 600 Ohm dynamic type	IF Rejection	More than 80 dB at 455 KHz
AC Input Voltage	110V 60Hz (220V 50Hz)	AGC	Change in audio output less than 12 dB from 10 μ V to 0.4V
AC Power Consumption	300W	Squelch	Adjustable-threshold less than 0.7 μ V
Antenna Connectors	Standard SO-239 type	Audio Frequency Response	400 to 2500 Hz
Meter #1	Indicates relative RF power output / antenna SWR	Distortion	Less than 10% at 2 watts output into 8 Ohms
Meter #2	Indicates received signal strength	Adjacent Channel Rejection	>75dB
<i>Transmitter</i>		Cross Modulation	>50 dB
Power Output	AM/FM 50W LSB/USB/CW 100W	Intermediate Frequency	10.695 MHz [AM-1st, SSB], 455 KHz [AM-2nd]
SSB Generation	Dual-Balanced modulation	Clarifier Range	\pm 1.5 KHz
Am Modulation	Class B amplitude, collectors modulation	Noise Blanker	IF single gate type
AM Modulation Capability	Up to 100%	Audio Output Power	More than 3 watts into 8 Ohms
FM Deviation	\pm 1.5KHz @ 1,250 Hz 2mV audio	Built In speaker	8 Ohms, dynamic
Harmonic and Spurious Emission	Better than 60dB	External Speaker (optional)	Disables internal speaker when connected
SSB Frequency Response	400 to 3000Hz		
Output Impedance	50 Ohms unbalanced		
Output Indicators	RF Meter shows relative RF output power		

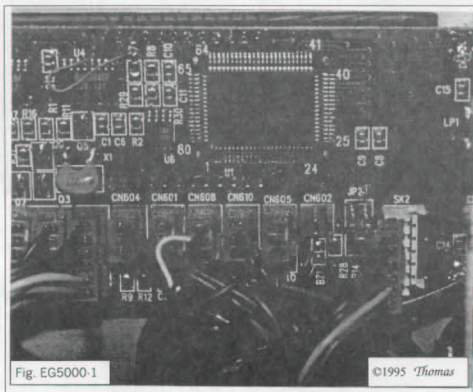

Channel Conversion Instructions

Step 1.) First remove all the screws holding the top cover and the side handle knobs in place. Remove the top cover. Next position the unit so that you are viewing it from a the rear. Locate the PC display board that is mounted to the front of the radio as shown in Fig. EG5000-1 above.

Step 2.) Next locate the Jumper labeled JP2 located in the lower right side of this board. You should find that the top pins have a jumper connector across them and the bottom pins are open. This is the standard default setup as shipped from the factory. In this configuration the radio will operate solely on the 10 Meter Amateur Band (28.0 to 29.7 MHz). The table below will provide you with more options for JP2.

JP2 Configuration	Radio Operating Range	Note
Top jumper installed , Bottom jumper <i>not</i> installed	10 Meter Amateur Band (28.0 to 29.7 MHz)	* Factory Default Setting
Both jumpers not installed	CB Band Only (26.965 to 27.405 MHz)	*Normal CB Radio Operation
Top jumper <i>not</i> installed, Bottom jumper installed	Partial Coverage (26.0 to 29.7 MHz)	
Top jumper installed and Bottom jumper installed	Full Coverage (26.0 to 32.0 MHz)	* Will need to obtain an extra jumper

RCI 2980
Channel Conversion

Channel Conversion Instructions

Step 1.) Turn the unit upside down with the front towards you and remove the eight screws holding the bottom cover. Set the bottom cover aside.

Step 2.) Next locate the wire (normally white) soldered to the circuit board as shown in Fig. RCI2980-1 below. Carefully unsolder this wire and remove.

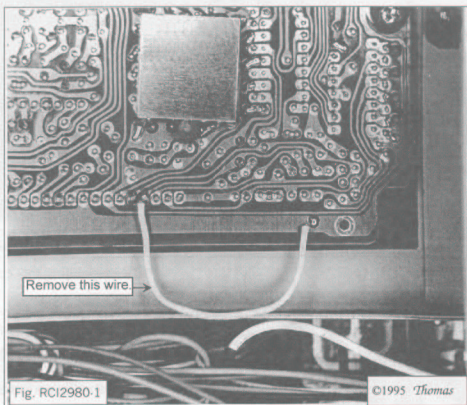

Step 3.) Before proceeding, be sure that you have no solder touching on any of the pins after removing this wire. Proceed to step 4 on the next page.

Note: Wire color may vary in some versions. However the instructions for conversion remains the same.

Step 4.)

Now locate the solder connection as shown in Fig. RCI2980-2. Using solder wick, carefully desolder this connection, separating these two solder joints. Be sure that you unsolder only the connection between these two pins. Proceed to Step 5 below.

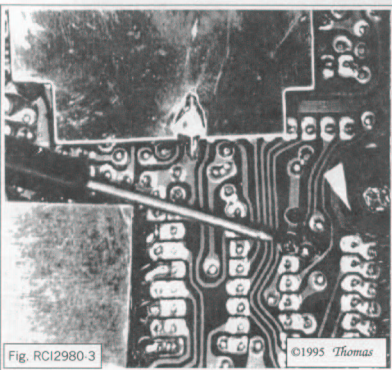
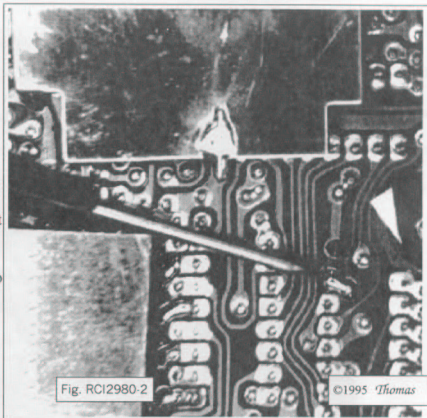

Step 5.)

After separating this connection, carefully check for any shorts or solder bridges that may have occurred while performing Step 4.

The connection should now appear as shown in Fig. RCI2980-3. Once you are sure that everything is ok, proceed to Step 6 on the following page.

RCI-2980
Channel Conversion

Step 6.) The next step is to locate the purple wire that was left unsoldered or cut from the band selector switch at the factory. Fig. RCI2980-4 below shows the band selector switch with the small stub connected to it.

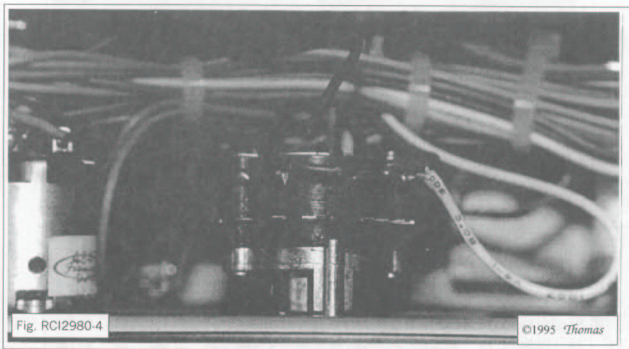

Step 7.) Once you have located this wire carefully solder it to the band selector switch as shown in Fig. RCI2980-5. Again take care and do not use excessive heat when resoldering this connection.

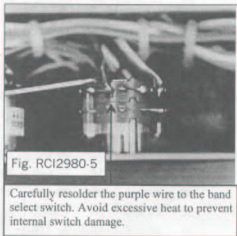

Step 8.) At this point your radio will now cover from 25.615 to 28.305 MHz as shown on the frequency chart for the RCI-2980 on the following page.

RCI-2980 FREQUENCY CHANNEL CHART

A		B		C		D		E		F	
Channel	Frequency	Channel	Frequency	Channel	Frequency	Channel	Frequency	Channel	Frequency	Channel	Frequency
1	25.615	1	26.065	1	26.515	1	26.965	1	27.415	1	27.865
2	25.625	2	26.075	2	26.525	2	26.975	2	27.425	2	27.875
3	25.635	3	26.085	3	26.535	3	26.985	3	27.435	3	27.885
4	25.655	4	26.105	4	26.555	4	27.005	4	27.455	4	27.905
5	25.665	5	26.115	5	26.565	5	27.015	5	27.465	5	27.915
6	25.675	6	26.125	6	26.575	6	27.025	6	26.475	6	27.925
7	25.685	7	26.135	7	26.585	7	27.035	7	27.485	7	27.935
8	25.705	8	26.155	8	26.605	8	27.055	8	27.505	8	27.955
9	25.715	9	26.165	9	26.615	9	27.065	9	27.515	9	27.965
10	25.725	10	26.175	10	26.625	10	27.075	10	27.525	10	27.975
11	25.735	11	26.185	11	26.635	11	27.085	11	27.535	11	27.985
12	25.755	12	26.205	12	26.655	12	27.105	12	27.555	12	28.005
13	25.765	13	26.215	13	26.665	13	27.115	13	27.565	13	28.015
14	25.775	14	26.225	14	26.675	14	27.125	14	27.575	14	28.015
15	25.785	15	26.235	15	26.685	15	27.135	15	27.585	15	28.025
16	25.805	16	26.255	16	26.705	16	27.155	16	27.605	16	28.035
17	25.815	17	26.265	17	26.715	17	27.165	17	27.615	17	28.055
18	25.825	18	26.275	18	26.725	18	27.175	18	27.625	18	28.065
19	25.835	19	26.285	19	26.735	19	27.185	19	27.635	19	28.075
20	25.855	20	26.305	20	26.755	20	27.205	20	27.655	20	28.085
21	25.865	21	26.315	21	26.765	21	27.215	21	27.665	21	28.105
22	25.875	22	26.325	22	26.775	22	27.225	22	27.675	22	28.115
23	25.905	23	26.355	23	26.805	23	27.255	23	27.705	23	28.155
24	25.885	24	26.335	24	26.785	24	27.235	24	27.685	24	28.135
25	25.895	25	26.345	25	26.795	25	27.245	25	27.695	25	28.145
26	25.915	26	26.365	26	26.815	26	27.265	26	27.715	26	28.165
27	25.925	27	26.375	27	26.825	27	27.275	27	27.725	27	28.175
28	25.935	28	26.385	28	26.835	28	27.285	28	27.735	28	28.185
29	25.945	29	26.395	29	26.845	29	27.295	29	27.745	29	28.195
30	25.955	30	26.405	30	26.855	30	27.305	30	27.755	30	28.205
31	25.965	31	26.415	31	26.865	31	27.315	31	27.765	31	28.215
32	25.975	32	26.425	32	26.875	32	27.325	32	27.775	32	28.225
33	25.985	33	26.435	33	26.885	33	27.335	33	27.785	33	28.235
34	25.995	34	26.445	34	26.895	34	27.345	34	27.795	34	28.245
35	26.005	35	26.455	35	26.905	35	27.355	35	27.805	35	28.255
36	26.015	36	26.465	36	26.915	36	27.365	36	27.815	36	28.265
37	26.025	37	26.475	37	26.925	37	27.375	37	27.825	37	28.275
38	26.035	38	26.485	38	26.935	38	27.385	38	27.835	38	28.285
39	26.045	39	26.495	39	26.945	39	27.395	39	27.845	39	28.295
40	26.055	40	26.505	40	26.955	40	27.405	40	27.855	40	28.305

RCI- 2990
Channel Conversion

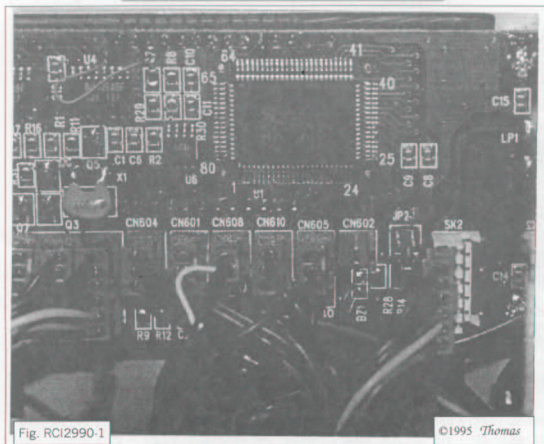

Channel Conversion Instructions

Step 1.) First remove all the screws holding the top cover and the side handle knobs in place. Remove the top cover. Next position the unit so that you are viewing it from a rear. Locate the PC display board that is mounted to the front of the radio as shown in Fig. RCI2990-1 above.

Step 2.) Next locate the Jumper labeled JP2 located in the lower right side of this board. You should find that the top pins have a jumper connector across them and the bottom pins are open. This is the standard default setup as shipped from the factory. In this configuration the radio will operate solely on the 10 Meter Amateur Band (28.0 to 29.7 MHz). The table below will provide you with more options for JP2.

JP2 Configuration	Radio Operating Range	Note
Top jumper installed , Bottom jumper <i>not</i> installed	10 Meter Amateur Band (28.0 to 29.7 MHz)	* Factory Default Setting
Both jumpers not installed	CB Band Only (26.965 to 27.405 MHz)	*Normal CB Radio Operation
Top jumper <i>not</i> installed, Bottom jumper installed	Partial Coverage (26.0 to 29.7 MHz)	
Top jumper installed and Bottom jumper installed	Full Coverage (26.0 to 32.0 MHz)	* Will need to obtain an extra jumper

GALAXY DX 33HML
CHANNEL CONVERSION

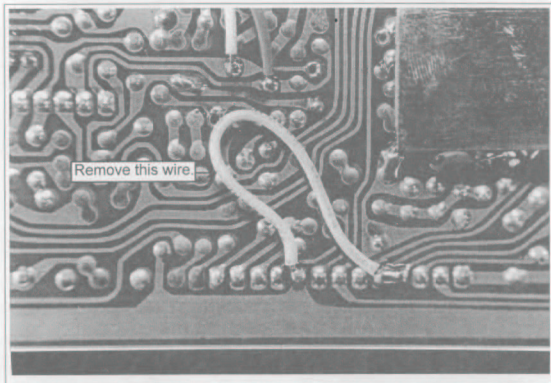

Channel Conversion Instructions

- Step 1.) Remove the screws holding the covers in place . Remove the top cover and set aside.
- Step 2.) Next locate the wire (normally white) soldered to the circuit board as shown in Fig. 33HML above. Carefully unsolder this wire and remove.
- Step 3.) Before proceeding, be sure that you have no solder touching on any of the pins after removing this wire. Your radio will now cover from 26.615 to 28.215 as shown in the channel chart on the following page.

Note: Wire color may vary in some versions. However the instructions for conversion remains the same.

GALAXY DX 33XML FREQUENCY CHANNEL CHART

LOW BAND						HIGH BAND					
A-Band		B-Band		C-Band		D-Band		E-Band		F-Band	
Channel	Frequency	Channel	Frequency	Channel	Frequency	Channel	Frequency	Channel	Frequency	Channel	Frequency
1	25.615	1	26.065	1	26.515	1	26.965	1	27.415	1	27.865
2	25.625	2	26.075	2	26.525	2	26.975	2	27.425	2	27.875
3	25.635	3	26.085	3	26.535	3	26.985	3	27.435	3	27.885
4	25.655	4	26.105	4	26.555	4	27.005	4	27.455	4	27.905
5	25.665	5	26.115	5	26.565	5	27.015	5	27.465	5	27.915
6	25.675	6	26.125	6	26.575	6	27.025	6	26.475	6	27.925
7	25.685	7	26.135	7	26.585	7	27.035	7	27.485	7	27.935
8	25.705	8	26.155	8	26.605	8	27.055	8	27.505	8	27.955
9	25.715	9	26.165	9	26.615	9	27.065	9	27.515	9	27.965
10	25.725	10	26.175	10	26.625	10	27.075	10	27.525	10	27.975
11	25.735	11	26.185	11	26.635	11	27.085	11	27.535	11	27.985
12	25.755	12	26.205	12	26.655	12	27.105	12	27.555	12	28.005
13	25.765	13	26.215	13	26.665	13	27.115	13	27.565	13	28.015
14	25.775	14	26.225	14	26.675	14	27.125	14	27.575	14	28.015
15	25.785	15	26.235	15	26.685	15	27.135	15	27.585	15	28.025
16	25.805	16	26.255	16	26.705	16	27.155	16	27.605	16	28.035
17	25.815	17	26.265	17	26.715	17	27.165	17	27.615	17	28.055
18	25.825	18	26.275	18	26.725	18	27.175	18	27.625	18	28.065
19	25.835	19	26.285	19	26.735	19	27.185	19	27.635	19	28.075
20	25.855	20	26.305	20	26.755	20	27.205	20	27.655	20	28.085
21	25.865	21	26.315	21	26.765	21	27.215	21	27.665	21	28.105
22	25.875	22	26.325	22	26.775	22	27.225	22	27.675	22	28.115
23	25.905	23	26.355	23	26.805	23	27.255	23	27.705	23	28.155
24	25.885	24	26.335	24	26.785	24	27.235	24	27.685	24	28.135
25	25.895	25	26.345	25	26.795	25	27.245	25	27.695	25	28.145
26	25.915	26	26.365	26	26.815	26	27.265	26	27.715	26	28.165
27	25.925	27	26.375	27	26.825	27	27.275	27	27.725	27	28.175
28	25.935	28	26.385	28	26.835	28	27.285	28	27.735	28	28.185
29	25.945	29	26.395	29	26.845	29	27.295	29	27.745	29	28.195
30	25.955	30	26.405	30	26.855	30	27.305	30	27.755	30	28.205
31	25.965	31	26.415	31	26.865	31	27.315	31	27.765	31	28.215
32	25.975	32	26.425	32	26.875	32	27.325	32	27.775	32	28.225
33	25.985	33	26.435	33	26.885	33	27.335	33	27.785	33	28.235
34	25.995	34	26.445	34	26.895	34	27.345	34	27.795	34	28.245
35	26.005	35	26.455	35	26.905	35	27.355	35	27.805	35	28.255
36	26.015	36	26.465	36	26.915	36	27.365	36	27.815	36	28.265
37	26.025	37	26.475	37	26.925	37	27.375	37	27.825	37	28.275
38	26.035	38	26.485	38	26.935	38	27.385	38	27.835	38	28.285
39	26.045	39	26.495	39	26.945	39	27.395	39	27.845	39	28.295
40	26.055	40	26.505	40	26.955	40	27.405	40	27.855	40	28.305

GALAXY DX 44U CHANNEL CONVERSION

Step 1. Remove the radio case and locate the small circuit board (EPT004410Z board) connected to the left side of the radio as viewed from the component side.

Step 2. Once you have located this small circuit board, locate the wire (usually white, but wire color may vary) that is soldered to the back of this board. Either unsolder or cut one end of this wire loose from the board and seal the end with some small heat shrinkable tubing . This needs to be done in order to prevent this wire from ever causing a short, or possibly other damage to your radio. Or you may remove this wire completely.

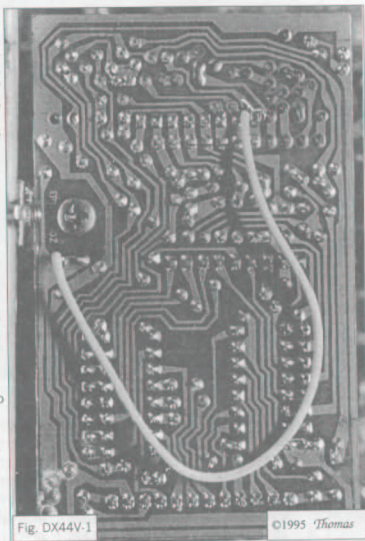

Step 3. Next look down past the channel board and to the right and locate the 3 pin plug as shown in the Fig. DX44V-2. This plug is normally labeled +10KHz and not connected at the factory. Once located carefully re-install and then proceed to Step 4 on the next page.

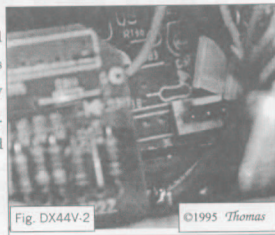

GALAXY DX 44U
CHANNEL CONVERSION

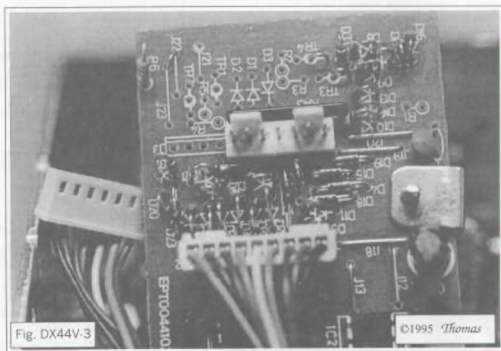

4. Next you will need to remove the small screw that holds this board to the radio case. Carefully turn this board so as to gain access to the component side.

5. Under this board you will find a 7 pin plug that was not connected at the factory. Carefully plug this connector to the board as shown in Fig. DX44V-3. Be sure the plug is plugged in properly and well seated. That's it. Your radio will now cover all channels & all bands as shown in the channel chart on the following page.

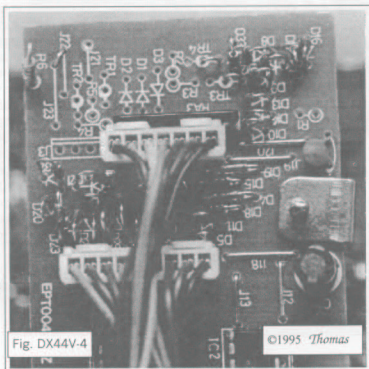

GALAXY DX 440 FREQUENCY CHANNEL CHART

LO BAND								HI BAND							
A		B		C		D		E		F		G		H	
Channel	Frequency	Channel	Frequency	Channel	Frequency	Channel	Frequency	Channel	Frequency	Channel	Frequency	Channel	Frequency	Channel	Frequency
1	25.165	1	25.615	1	26.065	1	26.515	1	26.965	1	27.415	1	27.865	1	28.315
2	25.175	2	25.625	2	26.075	2	26.525	2	26.975	2	27.425	2	27.875	2	28.325
3	25.185	3	25.635	3	26.085	3	26.535	3	26.985	3	27.435	3	27.885	3	28.335
4	25.205	4	25.655	4	26.105	4	26.555	4	27.005	4	27.455	4	27.905	4	28.355
5	25.215	5	25.665	5	26.115	5	26.565	5	27.015	5	27.465	5	27.915	5	28.365
6	25.225	6	25.675	6	26.125	6	26.575	6	27.025	6	27.475	6	27.925	6	28.375
7	25.235	7	25.685	7	26.135	7	26.585	7	27.035	7	27.485	7	27.935	7	28.385
8	25.255	8	25.705	8	26.155	8	26.605	8	27.055	8	27.505	8	27.955	8	28.405
9	25.265	9	25.715	9	26.165	9	26.615	9	27.065	9	27.515	9	27.965	9	28.415
10	25.275	10	25.725	10	26.175	10	26.625	10	27.075	10	27.525	10	27.975	10	28.425
11	25.285	11	25.735	11	26.185	11	26.635	11	27.085	11	27.535	11	27.985	11	28.435
12	25.305	12	25.755	12	26.205	12	26.655	12	27.105	12	27.555	12	28.005	12	28.455
13	25.315	13	25.765	13	26.215	13	26.665	13	27.115	13	27.565	13	28.015	13	28.465
14	25.325	14	25.775	14	26.225	14	26.675	14	27.125	14	27.575	14	28.015	14	28.475
15	25.335	15	25.785	15	26.235	15	26.685	15	27.135	15	27.585	15	28.025	15	28.485
16	25.355	16	25.805	16	26.255	16	26.705	16	27.155	16	27.605	16	28.035	16	28.505
17	25.365	17	25.815	17	26.265	17	26.715	17	27.165	17	27.615	17	28.055	17	28.515
18	25.375	18	25.825	18	26.275	18	26.725	18	27.175	18	27.625	18	28.065	18	28.525
19	25.385	19	25.835	19	26.285	19	26.735	19	27.185	19	27.635	19	28.075	19	28.535
20	25.405	20	25.855	20	26.305	20	26.755	20	27.205	20	27.655	20	28.085	20	28.555
21	25.415	21	25.865	21	26.315	21	26.765	21	27.215	21	27.665	21	28.105	21	28.565
22	25.425	22	25.875	22	26.325	22	26.775	22	27.225	22	27.675	22	28.115	22	28.575
23	25.455	23	25.905	23	26.355	23	26.805	23	27.255	23	27.705	23	28.155	23	28.605
24	25.435	24	25.885	24	26.335	24	26.785	24	27.235	24	27.685	24	28.135	24	28.585
25	25.445	25	25.895	25	26.345	25	26.795	25	27.245	25	27.695	25	28.145	25	28.595
26	25.465	26	25.915	26	26.365	26	26.815	26	27.265	26	27.715	26	28.165	26	28.615
27	25.475	27	25.925	27	26.375	27	26.825	27	27.275	27	27.725	27	28.175	27	28.625
28	25.485	28	25.935	28	26.385	28	26.835	28	27.285	28	27.735	28	28.185	28	28.635
29	25.495	29	25.945	29	26.395	29	26.845	29	27.295	29	27.745	29	28.195	29	28.645
30	25.505	30	25.955	30	26.405	30	26.855	30	27.305	30	27.755	30	28.205	30	28.655
31	25.515	31	25.965	31	26.415	31	26.865	31	27.315	31	27.765	31	28.215	31	28.665
32	25.525	32	25.975	32	26.425	32	26.875	32	27.325	32	27.775	32	28.225	32	28.675
33	25.535	33	25.985	33	26.435	33	26.885	33	27.335	33	27.785	33	28.235	33	28.685
34	25.545	34	25.995	34	26.445	34	26.895	34	27.345	34	27.795	34	28.245	34	28.695
35	25.555	35	26.005	35	26.455	35	26.905	35	27.355	35	27.805	35	28.255	35	28.705
36	25.565	36	26.015	36	26.465	36	26.915	36	27.365	36	27.815	36	28.265	36	28.715
37	25.575	37	26.025	37	26.475	37	26.925	37	27.375	37	27.825	37	28.275	37	28.725
38	25.585	38	26.035	38	26.485	38	26.935	38	27.385	38	27.835	38	28.285	38	28.735
39	25.595	39	26.045	39	26.495	39	26.945	39	27.395	39	27.845	39	28.295	39	28.745
40	25.605	40	26.055	40	26.505	40	26.955	40	27.405	40	27.855	40	28.305	40	28.755

NOTES

1. Remove the radio case and locate the small circuit board (EPT004410Z board) connected to the left side of the radio as viewed from the component side.

2. Once you have located this small circuit board, locate the wire (usually orange, but wire color may vary) that is soldered to the back of this board. Either unsolder or cut one end of this wire loose from the board and seal the end with some small heat shrinkable tubing . This needs to be done in order to prevent this wire from ever causing a short, or possibly other damage to your radio. Or you may remove this wire completely.

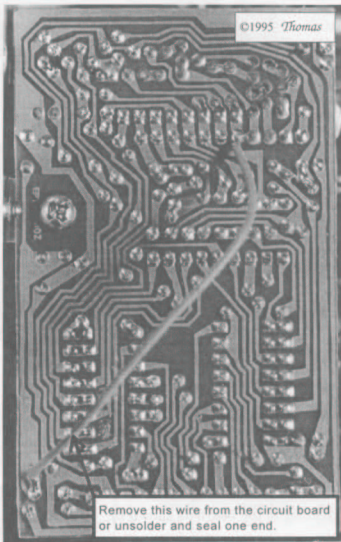

3. Next you will need to remove the small screw that this board to the radio case. Carefully turn this board so as to gain access to the component side.

Note: Wire color may vary in some versions. However the instructions for conversion remains the same.

GALAXY DX 99U
FREQUENCY MODIFICATION

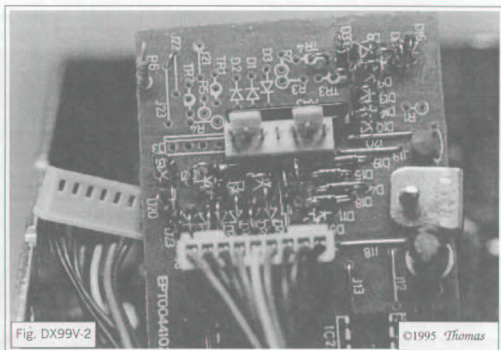

4. Under this board you will find a 7 pin plug that was not connected at the factory. Carefully plug this connector to the board as shown in Fig. DX99V-3. Be sure the plug is plugged in properly and well seated. That's it. Your radio will now cover all channels & all bands as shown in the channel chart on the following Page.

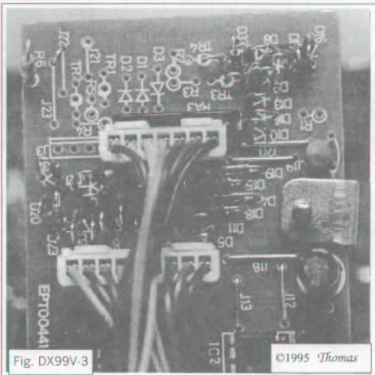

GALAXY DX 99U FREQUENCY CHANNEL CHART

LO BAND				HI BAND											
A		B		C		D		E		F		G		H	
Channel	Frequency	Channel	Frequency	Channel	Frequency	Channel	Frequency	Channel	Frequency	Channel	Frequency	Channel	Frequency	Channel	Frequency
1	25.165	1	25.615	1	26.065	1	26.515	1	26.965	1	27.415	1	27.865	1	28.315
2	25.175	2	25.625	2	26.075	2	26.525	2	26.975	2	27.425	2	27.875	2	28.325
3	25.185	3	25.635	3	26.085	3	26.535	3	26.985	3	27.435	3	27.885	3	28.335
4	25.205	4	25.655	4	26.105	4	26.555	4	27.005	4	27.455	4	27.905	4	28.355
5	25.215	5	25.665	5	26.115	5	26.565	5	27.015	5	27.465	5	27.915	5	28.365
6	25.225	6	25.675	6	26.125	6	26.575	6	27.025	6	27.475	6	27.925	6	28.375
7	25.235	7	25.685	7	26.135	7	26.585	7	27.035	7	27.485	7	27.935	7	28.385
8	25.255	8	25.705	8	26.155	8	26.605	8	27.055	8	27.505	8	27.955	8	28.405
9	25.265	9	25.715	9	26.165	9	26.615	9	27.065	9	27.515	9	27.965	9	28.415
10	25.275	10	25.725	10	26.175	10	26.625	10	27.075	10	27.525	10	27.975	10	28.425
11	25.285	11	25.735	11	26.185	11	26.635	11	27.085	11	27.535	11	27.985	11	28.435
12	25.305	12	25.755	12	26.205	12	26.655	12	27.105	12	27.555	12	28.005	12	28.455
13	25.315	13	25.765	13	26.215	13	26.665	13	27.115	13	27.565	13	28.015	13	28.465
14	25.325	14	25.775	14	26.225	14	26.675	14	27.125	14	27.575	14	28.015	14	28.475
15	25.335	15	25.785	15	26.235	15	26.685	15	27.135	15	27.585	15	28.025	15	28.485
16	25.355	16	25.805	16	26.255	16	26.705	16	27.155	16	27.605	16	28.035	16	28.505
17	25.365	17	25.815	17	26.265	17	26.715	17	27.165	17	27.615	17	28.055	17	28.515
18	25.375	18	25.825	18	26.275	18	26.725	18	27.175	18	27.625	18	28.065	18	28.525
19	25.385	19	25.835	19	26.285	19	26.735	19	27.185	19	27.635	19	28.075	19	28.535
20	25.405	20	25.855	20	26.305	20	26.755	20	27.205	20	27.655	20	28.085	20	28.555
21	25.415	21	25.865	21	26.315	21	26.765	21	27.215	21	27.665	21	28.105	21	28.565
22	25.425	22	25.875	22	26.325	22	26.775	22	27.225	22	27.675	22	28.115	22	28.575
23	25.455	23	25.905	23	26.355	23	26.805	23	27.255	23	27.705	23	28.155	23	28.605
24	25.435	24	25.885	24	26.335	24	26.785	24	27.235	24	27.685	24	28.135	24	28.585
25	25.445	25	25.895	25	26.345	25	26.795	25	27.245	25	27.695	25	28.145	25	28.595
26	25.465	26	25.915	26	26.365	26	26.815	26	27.265	26	27.715	26	28.165	26	28.615
27	25.475	27	25.925	27	26.375	27	26.825	27	27.275	27	27.725	27	28.175	27	28.625
28	25.485	28	25.935	28	26.385	28	26.835	28	27.285	28	27.735	28	28.185	28	28.635
29	25.495	29	25.945	29	26.395	29	26.845	29	27.295	29	27.745	29	28.195	29	28.645
30	25.505	30	25.955	30	26.405	30	26.855	30	27.305	30	27.755	30	28.205	30	28.655
31	25.515	31	25.965	31	26.415	31	26.865	31	27.315	31	27.765	31	28.215	31	28.665
32	25.525	32	25.975	32	26.425	32	26.875	32	27.325	32	27.775	32	28.225	32	28.675
33	25.535	33	25.985	33	26.435	33	26.885	33	27.335	33	27.785	33	28.235	33	28.685
34	25.545	34	25.995	34	26.445	34	26.895	34	27.345	34	27.795	34	28.245	34	28.695
35	25.555	35	26.005	35	26.455	35	26.905	35	27.355	35	27.805	35	28.255	35	28.705
36	25.565	36	26.015	36	26.465	36	26.915	36	27.365	36	27.815	36	28.265	36	28.715
37	25.575	37	26.025	37	26.475	37	26.925	37	27.375	37	27.825	37	28.275	37	28.725
38	25.585	38	26.035	38	26.485	38	26.935	38	27.385	38	27.835	38	28.285	38	28.735
39	25.595	39	26.045	39	26.495	39	26.945	39	27.395	39	27.845	39	28.295	39	28.745
40	25.605	40	26.055	40	26.505	40	26.955	40	27.405	40	27.855	40	28.305	40	28.755

NOTES

GALAXY DX 77HML & DX 88HL
 SUPER-TALK™ Installation Instructions

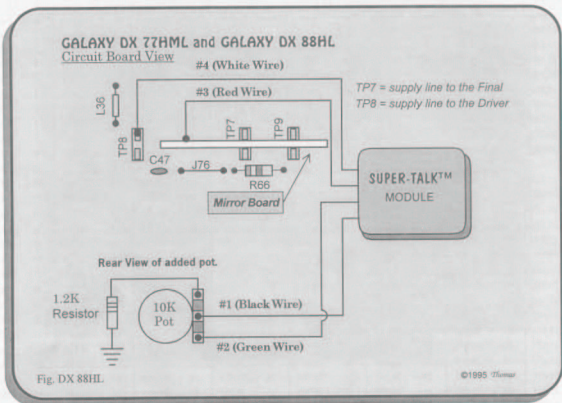

Installation Instructions

1. Locate the mirror board that connects TP9, TP8, and TP7 in the final section. Next slide this board to the right until it no longer makes a connection with TP8. Then solder the #4 white wire to the TP8 terminal and solder the #3 red wire directly to the side of the mirror board. Make sure that your solder connections are good and solid.

2. Next mount a 10K miniature pot in a convenient location and solder the other two wires of the SUPER-TALK module as shown and add the 1.2K resistor. Once completed you will have full variable power with excellent modulation capabilities.

Note: This SUPER-TALK installation is basically the same for many other Export and Domestic CB radios with the removable mirror board. It is important however that when you slide the mirror board over that it does not short against any other components. If you find that this is the case, insulate the end of the board with some electrical tape before proceeding with the installation.

COBRA® 148F-GTL

(New Frequency Counter Model)
Clarifier Modification

In the diagram below (Fig 148FCLS) we have shown the stock COBRA® 148F-GTL clarifier circuit before modification for reference. In Fig 148FCLM we have shown the same circuit after the clarifier circuit has been modified. This New Version is made in Malaysia and is no longer manufactured by Uniden.

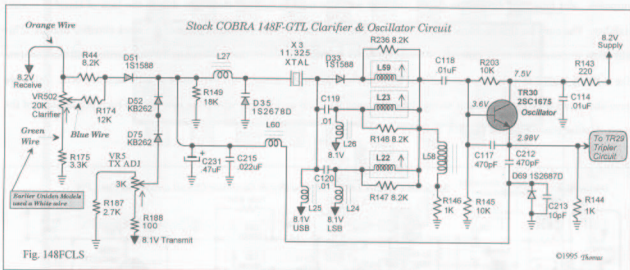

Modification Instructions

1. Locate D52 and R44 just to the right of the large 11.325 xtal in the clarifier circuit and cut one end as shown below. It doesn't matter which end of R44 and D52 you cut. Next locate R174 (12K Resistor) directly behind R44 and unsolder and remove it from the circuit. Next solder a jumper wire in place of R174.
2. Next trace the Green wire from the clarifier control to where it is soldered to the circuit board near C110, and cut it loose. Resolder the Green wire to the circuit board ground.
3. Next trace the Orange wire from the clarifier control and unsolder it from the circuit board. At this point you will need to add a small amount of wire to the orange wire in order to make it long enough to reach pin 3 of IC4 (MB3756 Regulator IC). IC4 is mounted to the side of the radio case about two inches back from the MIC socket. Now solder this wire to pin 3 of IC4. Pin 3 of IC4 (3rd pin from the back of the radio) has no other connections. Your clarifier will now track on receive and transmit.

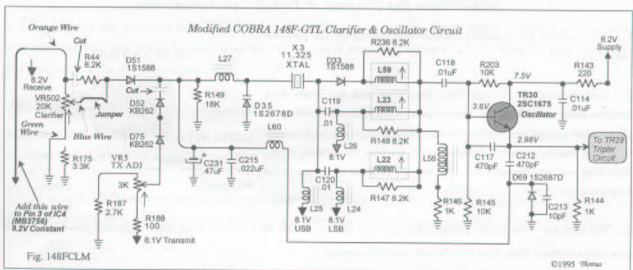

COBRA® 148F-GTL

(New Frequency Counter Model)
Super Slide Modification

In most cases once the clarifier circuit has been modified, the stock clarifier control is just not adequate for all practical purposes. Not only is it difficult to clarify, the unit will also tend to drift off frequency due to the lack of clarifier control stability. The cure for this problem is to install a 10-Turn Precision Potentiometer in place of the stock clarifier control. This will allow you cover the same range in 10 complete turns versus 1 turn with the stock control. Your clarifier will then operate like a FINE TUNE clarifier control and will have much improved stability, with very little or no frequency drift. Below we have shown what the above circuit should look like once modified and how to wire your new 20k-10 turn pot in place of the stock clarifier control for the COBRA 148F-GTL.

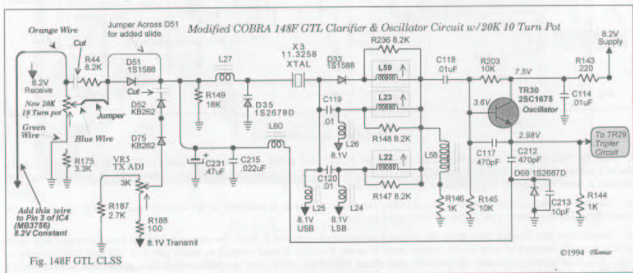

20K-10 Turn Pot Diagram & Installation Instructions

1. First perform the standard clarifier modification on the previous page.

2. Next unsolder the Orange Wire, Blue Wire, and the Green Wire from the stock clarifier control. At this point you will need to remove the old clarifier control and install the new 20K-10 turn pot in its place. Once that you have mounted the new pot, resolder the Orange Wire, Blue Wire, and the Green Wire to the new 10 turn pot as shown in the diagram to the right.

20K-10 TURN POT.

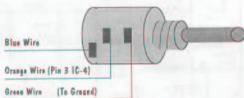
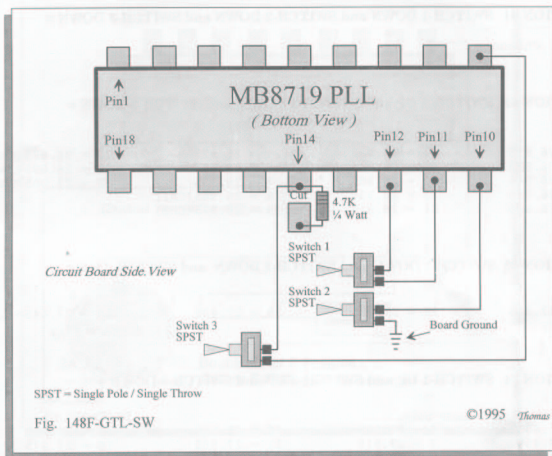

Fig. Pot-GTL

3. You may also want to add a jumper either across or in place D51 for increased slide. Once completed, your unit should now slide anywhere from 10 to 20 KHz with precision control.

COBRA® 148F-GTL

(New Frequency Counter Model)
Switch Channel Conversion



148F-GTL Channel Conversion Instructions

1. First locate Pin 14 of the MB8719 PLL chip on the bottom side of the circuit board. Using an ex-acto knife, carefully cut and isolate Pin 14 away from the circuit board run. Next solder a 4.7K $\frac{1}{4}$ Watt resistor across this cut as shown in the diagram above.
2. Next mount 3 SPST Toggle switches in a convenient location. Be sure to wire the switches up as shown, and to solder each wire carefully. Once all the wires have been soldered to the switches and to the circuit board as shown, check all solder joints before proceeding.
3. Now with all three switches in the down position you will still have the normal channels. Refer to the Cobra 148F-GTL Channel chart on the following page for the switch positions and their associated channels.

COBRA 148F-GTL*(New Frequency Counter Model)**Switch Channel Chart***POSITION #1 SWITCH-1 DOWN and SWITCH-2 DOWN and SWITCH-3 DOWN =**

Normal Channels

POSITION #2 SWITCH-1 UP and SWITCH-2 DOWN and SWITCH-3 DOWN =

15 = 26.815	20 = 26.885	25 = 26.925	30 = 26.985 (Ch3)
16 = 26.835	21 = 26.895	26 = 26.945	31 = 26.995 (3A)
17 = 26.845	22 = 26.905	27 = 26.955	32 = 27.005 (Ch4)
18 = 26.855	23 = 26.935	28 = 26.965 (Ch1)	
19 = 26.865	24 = 26.915	29 = 26.975 (Ch2)	

POSITION #3 SWITCH-1 DOWN and SWITCH-2 DOWN and SWITCH-3 UP =

37 = 27.415	38 = 27.425	39 = 27.435	40 = 27.445
-------------	-------------	-------------	-------------

POSITION #4 SWITCH-1 UP and SWITCH-2 UP and SWITCH-3 DOWN =

1 = 27.605	6 = 27.505	10 = 27.555	14 = 27.605
2 = 27.455	7 = 27.515	11 = 27.565	16 = 27.475
3 = 27.465	8 = 27.535	12 = 27.585	20 = 27.525
4 = 27.485	9 = 27.545	13 = 27.595	23 = 27.575
5 = 27.495			

POSITION #5 SWITCH-1 DOWN and SWITCH-2 UP and SWITCH-3 DOWN =

1 = 27.605	11 = 27.725	21 = 27.855	31 = 27.955
2 = 27.615	12 = 27.745	22 = 27.865	32 = 27.965
3 = 27.625	13 = 27.755	23 = 27.895	33 = 27.975
4 = 27.645	14 = 27.765	24 = 27.875	34 = 27.985
5 = 27.655	15 = 27.775	25 = 27.885	35 = 27.995
6 = 27.665	16 = 27.795	26 = 27.905	36 = 28.005
7 = 27.675	17 = 27.805	27 = 27.915	37 = 28.015
8 = 27.695	18 = 27.815	28 = 27.925	38 = 28.025
9 = 27.705	19 = 27.825	29 = 27.935	39 = 28.035
10 = 27.715	20 = 27.845	30 = 27.945	40 = 28.045

COBRA® 148F-GTL
(New Frequency Counter Model)
Rotary Switch Channel Conversion

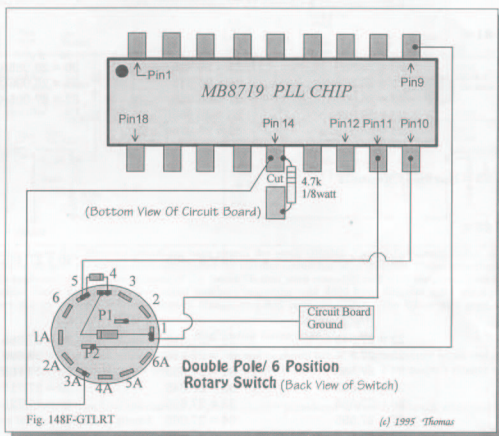

Rotary Switch Channel Conversion Instructions

1. Obtain a Double Pole / 6 Position Rotary Switch. Be sure to get the Break Before Make type. You will also need 2 small signal diodes (1N914, 1N4148 or Equivalent), a piece of 5 wire ribbon cable long enough to reach from the switch to the PLL chip connections, and 1 / 4.7k 1/4 watt resistor. Next solder the diodes to the switch as shown in the diagram above. Be sure that the cathode ends (Banded) are as shown once you have completed this step. The diode that connects between Pin 4 & Pin 5 should have the banded end to Pin 4 and the diode that connects between Pin 1 & Pin 4 should also have the banded end to Pin 4.

2. Next locate Pin 14 of the PLL and using an ex-acto knife carefully isolate Pin 14 as shown above. Next solder the 4.7k resistor across this cut in order to allow Pin 14 to operate at its normal state. Once this has been done you may connect the ribbon cable to switch - prior to mounting in its permanent location. Be sure that the wires are connected as shown in the above diagram. Once that you have mounted the switch you may then make the connections to the PLL chip as shown above. Re-check all your connections before turning the unit on. The channel chart on the next page shows your new frequencies. Check all positions of the switch for these channels. Some adjustment of the VCO coil (L19) may be necessary in some cases for full channel coverage.

COBRA® 148F-GTL*(New Malaysian Model)**Rotary Switch Channel Chart***POSITION #1 =**

15 = 26.815	20 = 26.885	25 = 26.925	30 = 26.985(Ch3)
16 = 26.835	21 = 26.895	26 = 26.945	31 = 26.995(3A)
17 = 26.845	22 = 26.905	27 = 26.955	32 = 27.005(Ch4)
18 = 26.855	23 = 26.935	28 = 26.965(Ch1)	
19 = 26.865	24 = 26.915	29 = 26.975(Ch2)	

POSITION #2 = Normal Channels**POSITION #3 =**

37 = 27.415	38 = 27.425	39 = 27.435	40 = 27.445
-------------	-------------	-------------	-------------

POSITION #4 =

15 = 27.455	22 = 27.545	29 = 27.615	36 = 27.685
16 = 27.465	23 = 27.575	30 = 27.625	37 = 27.695
17 = 27.475	24 = 27.555	31 = 27.635	38 = 27.705
18 = 27.495	25 = 27.565	32 = 27.645	39 = 27.715
19 = 27.505	26 = 27.585	33 = 27.655	40 = 27.725
20 = 27.525	27 = 27.595	34 = 27.665	
21 = 27.535	28 = 27.605	35 = 27.675	

POSITION #5 =

1 = 27.605	11 = 27.725	21 = 27.855	31 = 27.955
2 = 27.615	12 = 27.745	22 = 27.865	32 = 27.965
3 = 27.625	13 = 27.755	23 = 27.895	33 = 27.975
4 = 27.645	14 = 27.765	24 = 27.875	34 = 27.985
5 = 27.655	15 = 27.775	25 = 27.885	35 = 27.995
6 = 27.665	16 = 27.795	26 = 27.905	36 = 28.005
7 = 27.675	17 = 27.805	27 = 27.915	37 = 28.015
8 = 27.695	18 = 27.815	28 = 27.925	38 = 28.025
9 = 27.705	19 = 27.825	29 = 27.935	39 = 28.035
10 = 27.715	20 = 27.845	30 = 27.945	40 = 28.045

POSITION #6 = Normal Channels

UNIDEN GRANT-XL Clarifier Modification Update

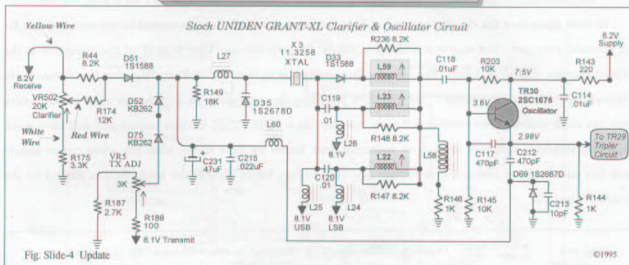

In the diagram above (Fig Slide-4 Update) we have shown the stock GRANT XL clarifier circuit before modification for reference. Below we have shown the same circuit after the clarifier circuit has been modified. Please note that these updated modifications apply only to the later versions of the Grant-XL that were manufactured with serial numbers beginning with the 4500 series. Later models that have serial numbers beginning with 4500 have different color wires on the clarifier control. They are as follows ; Yellow instead of orange, and Red instead of Blue. The White wire is the same in both versions.

Modification Instructions

1. Locate D52 and R44 in the clarifier circuit and cut one end as shown below. It doesn't matter which end of R44 and D52 you cut. Next locate R174 (12K Resistor) and unsolder and remove it from the circuit. Next solder a jumper wire in place of R174.
2. Next trace the White wire from the clarifier control to where it is soldered to the circuit board, and cut it loose. Resolder the white wire to the circuit board ground.
3. Next trace the Yellow wire from the clarifier control and unsolder it from the circuit board. At this point you will need to add a small amount of wire to the yellow wire in order to make it long enough to reach pin 3 of IC4 (MB3756 Regulator IC). Now solder this wire to pin 3 of IC4. Your clarifier will now track on receive and transmit.

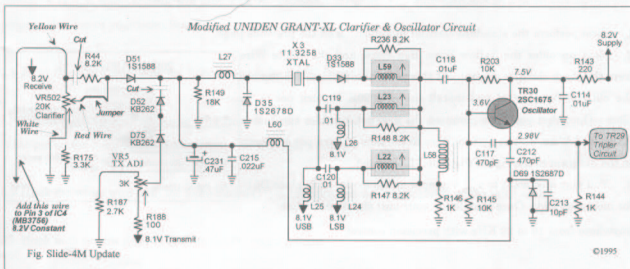

UNIDEN GRANT-XL Super Slide Clarifier Modification Update

In most cases once the clarifier circuit has been modified, the stock clarifier control is just not adequate for all practical purposes. Not only is it difficult to clarify, the unit will also tend to drift off frequency due to the lack of clarifier control stability. The cure for this problem is to install a 10-Turn Precision Potentiometer in place of the stock clarifier control. This will allow you cover the same range in 10 complete turns versus 1 turn with the stock control. Your clarifier will then operate like a FINE TUNE clarifier control and will have much improved stability, with very little or no frequency drift. Below we have shown what the above circuit should look like once modified and how to wire your new 20k- 10 turn pot in place of the stock clarifier control for the Uniden Grant XL.

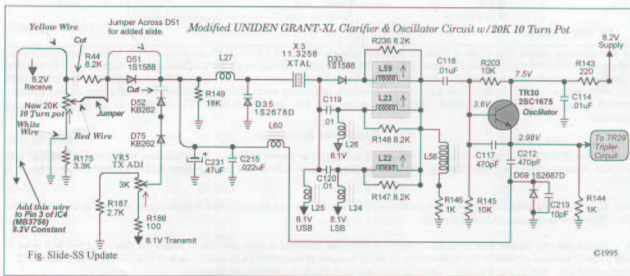

20K-10 Turn Pot Diagram & Installation Instructions

1. First perform the standard clarifier modification on the previous page.
2. Next unsolder the Yellow Wire, Red Wire, and the White Wire from the stock clarifier control. At this point you will need to remove the old clarifier control and install the new 20K-10 turn pot in its place. Once that you have mounted the new pot, resolder the Yellow Wire, Red Wire, and the White Wire to the new 10 turn pot as shown in the diagram to the right (Fig. Pot-XL Update).
3. You may also want to add a jumper either across or in place D51 for increased slide. Once completed, your unit should now slide anywhere from 10 to 20 KHz with precision control.

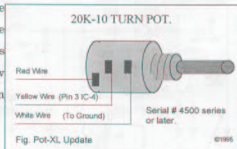

EPTOSSB50B ECHOBOARD INSTALLATION INSTRUCTIONS

Caution: This is an 8 to 10 volt Echo Board. 12 volt hookup will cause Echo override and feedback .

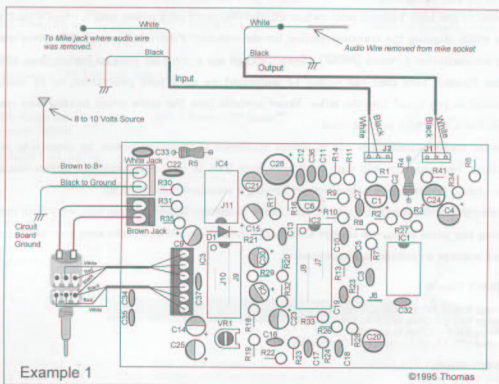

- 1.) Hook the brown wire from the Echo Board to 8 to 10 volt source while the radio is in transmit mode. If you are unable to locate an 8 to 10 volt transmit source you may need to use a higher voltage source such as a 11 to 13.8 volt transmit source which will require a dropping resistor in series with the brown wire to provide an 8 to 10 volt source. A 1K (1/2 watt) resistor will drop 13.8 volts to about 8.7 volts. You must maintain an 8 to 10 volt source for proper operation of your Echo Board.
- 2.) Hook the Black wire from the Echo Board to Radio PC Board Ground.
- 3.) Locate and unsolder the Audio wire from the mike socket. Next hook the white wire from the Echo Board (J2) to the pin on the mike socket at this point. (See Example 1 above.)
- 4.) Hook the white wire from the Echo Board (J1) to the wire that was unhooked from the mike socket.
- 5.) Hook both shields from J1 & J2 to the PC board ground.

RADIO TRANSMIT MODIFICATION SECTION

As many of you have noticed, most radios will develop more peak power with a whistle than when using normal voice when aligning the transmit section for more power. First of all you should never use a whistle when tuning for maximum forward (*PEAK*) power. Instead use a constant tone no higher than 300 to 400 Hz (Normal Voice Range). This tone can either be generated by most tone generators, or by using a steady ah-h-h-h-h sound as you speak into the mike. *Never whistle into the mike when tuning any radio*, unless your customer has a very high pitched voice.

The following modifications allow you to obtain maximum peak output power, by increasing normal voice range sensitivity. Improvement will vary anywhere from 25% to 50% depending the radios' circuitry. These modifications should be performed only after performing a standard radio tune-up.

We have also shown the nominal value of most parts to change, however these may vary from radio to radio. When replacing any parts be sure to change or use only those specified and make sure your replacement has at least the same wattage or voltage rating or greater.

Cobra 25 LTD-WX Classic

1. Change R76 (2.2K) to a 1K. (Located near mike socket)
2. Change R43 (10 Ohm) to a 2.7 Ohm.
3. Change R108 (1 Ohm) to a .47 Ohm.
4. Re-tune L10, L9, L8 for maximum Forward Power.

Cobra 29LTD-WX Classic

1. Change R58 (8 Ohm) to a 2.7 Ohm
2. Change R123 (1 Ohm) to a .47 Ohm
3. Re-Tune L14, L13, L12 for maximum Forward Power

Uniden Grant XI

1. Remove TR24
2. Change R126 (10K) to a 2.2k
3. Change R124 (10K) to a 4.7K
4. Re-Tune L37, L38 for maximum Forward Power on AM.

Uniden PC 66XL

1. Change R76 (2.2K) to a 1K
2. Change R43 (10 Ohm) to a 2.7 Ohm
3. Change R108 (1 Ohm) to a .47 Ohm
4. Re-Tune L13, L10, L9, L8 for maximum Forward Power.

Uniden PC 76XL & Uniden PC 76XLW

1. Change R58 (.8.2 Ohm) to a 2.7 Ohm
2. Change R123 (1 Ohm) to a .47 Ohm
3. Re-Tune L14, L13, L12 for maximum Forward Power

Uniden PC-122XL

1. Remove Q27 (Behind Squelch adjustment on circuit board).
2. Change 10K resistor between mike white audio lead and collector of Q27 to a 1K.
3. Change 10K resistor between base of Q26 and disc Capacitor from collector of Q27 to a 1K.
4. Re-Tune for Maximum Forward Power.

VARIABLE ALIGNMENTS SECTION

COBRA RADIOS

148F GTL (EPT014811Z Board) (New model w/Frequency Counter)

VR1 = AM "S" Meter	VR5 = Transmit Freq. Adjust	VR9 = Driver Bias Adjust
VR2 = SSB RX Meter	VR6 = RF Transmit Meter	VR10 = AM Power Adjust
VR3 = Squelch Range Adjust	VR7 = Modulation AMC	VR11 = SSB ALC Adjust
VR4 = Carrier Balance Adjust	VR8 = Final Bias Adjust	

Receive Alignment = L14, L12, L10, L9, L8, L7, L15, L13, L3, L6, L5, L4
Transmit Alignment = L47, L48, L46, L45, L38

19DX LTD

RV1 = Squelch Range Adjust	RV3 = Receive "S" Meter	RV4 = RF Transmit Meter
RV2 = Modulation Adjust		

Receive Alignment = L1, L2, L3
Transmit Alignment = L5, L6, L201

93 LTD WX

VR1 = Receive "S" Meter	VR3 = Modulation Adjust	VR4 = Squelch Range Adjust
VR2 = RF Transmit Meter		

Receive Alignment = L1, L2, L3, L4
Transmit Alignment = L16, L17, L18

DIRLAND RADIOS

SS-3000B

VR1 = AM/FM "S" Meter	VR8 = RF Transmit Meter	VR14 = Hi Power Modulation AMC
VR4 = Squelch Range Adjust	VR12 = Low Power Modulation AMC	VR16 = AM Low power Adjust
VR5 = FM Deviation Adjust	VR13 = AM Hi Power Adjust	

Receive Alignment = L1, L2, L3, L4, L5, L6, L7, L8
Transmit Alignment = L44, L43, L42, L33,

EAGLE RADIOS

Eagle 2000 (EPT 360014B Board)

VR1 = AM "S" Meter	VR7 = Carrier Balance	VR13 = AM High Power Adjust
VR2 = SSB/CW "S" Meter	VR8 = RF Transmit Meter	VR14 = AM Modulation AMC Adjust
VR3 = SSB Squelch Range	VR10 = Final TX Bias Adjust (1)	VR16 = AM Low Power Adjust
VR4 = AM Squelch Range	VR11 = Driver TX Bias Adjust	VR20 = Final TX Bias (2)
VR5 = FM Deviation	VR12 = ALC SSB Power	VR21 = Transmit Frequency Adjust

Receive Adjust = L1, L2, L3, L4, L5, L6, L7, L8, L10, L11, L12
Transmit Adjust = L44, L43, L42, L40, L33, L31 (Spreadable Coil)

Eagle 5000 (EPT 295013Z Board)

VR1 = AM "S" Meter	VR7 = Carrier Balance	VR13 = AM High Power Adjust
VR2 = SSB/CW "S" Meter	VR8 = RF Transmit Meter	VR14 = AM Modulation AMC Adjust
VR3 = SSB Squelch Range	VR11 = Driver TX Bias Adjust	VR15 = CW Level Adjust
VR4 = AM Squelch Range	VR12 = ALC SSB Power	VR16 = AM Low Power Adjust
		VR21 = FM Deviation Adjust

Receive Adjust = L9, L11, L12, L13, L14, L3, L4, L5, L6
Transmit Adjust = L46, L47, L48, L43, L34

VARIABLE ALIGNMENTS SECTION

GALAXY RADIOS

DX 99V (EPT 360014B Board)

VR1 = AM "S" Meter
VR2 = SSB/CW "S" Meter
VR3 = SSB Squelch Range
VR4 = AM Squelch Range
VR5 = FM Deviation

VR7 = Carrier Balance
VR8 = RF Transmit Meter
VR10 = Final TX Bias Adjust (1)
VR11 = Driver TX Bias Adjust
VR12 = ALC SSB Power

VR13 = AM High Power Adjust
VR14 = AM Modulation AMC Adjust
VR16 = AM Low Power Adjust
VR20 = Final TX Bias (2)
VR21 = Transmit Frequency Adjust

Receive Adjust = L1, L2, L3, L4, L5, L6, L7, L8
Transmit Adjust = L44, L43, L42, L40, L33

MIRAGE 88 (EPT 360014B Board)

VR1 = AM "S" Meter
VR2 = SSB/CW "S" Meter
VR3 = SSB Squelch Range
VR4 = AM Squelch Range
VR5 = FM Deviation

VR7 = Carrier Balance
VR8 = RF Transmit Meter
VR10 = Final TX Bias Adjust (1)
VR11 = Driver TX Bias Adjust
VR12 = ALC SSB Power

VR13 = AM High Power Adjust
VR14 = AM Modulation AMC Adjust
VR16 = AM Low Power Adjust
VR20 = Final TX Bias (2)
VR21 = Transmit Frequency Adjust

Receive Adjust = L1, L2, L3, L4, L5, L6, L7, L8
Transmit Adjust = L44, L43, L42, L40, L33

MAXON® RADIOS

MCB-60

RV101 = Squelch Range Adjust
RV102 = Receive Meter Adjust

RV201 = Modulation AMC adjust
RV301 = Transmit Meter Adjust

RV302 = SWR Meter Calibrate

Receive Adjust = L101, L102, L103, L104, L105, L106, L107, L108, L109
Transmit Adjust = L301, L302, L303, L304, L305, L306

MIDLAND RADIOS

77-104XL

VR3 = Squelch Range Adjust

VR4 = Modulation Adjust

Receive Adjust = T-1, T-2, T-3, T-4, T-5
Transmit Adjust = T-8, T-9, T-10, L-3, L-6, L-7

RANGER RADIOS

RCI 2980 (EPT 360014B Board)

VR1 = AM "S" Meter
VR2 = SSB/CW "S" Meter
VR3 = SSB Squelch Range
VR4 = AM Squelch Range
VR5 = FM Deviation

VR7 = Carrier Balance
VR8 = RF Transmit Meter
VR10 = Final TX Bias Adjust (1)
VR11 = Driver TX Bias Adjust
VR12 = ALC SSB Power

VR13 = AM High Power Adjust
VR14 = AM Modulation AMC Adjust
VR16 = AM Low Power Adjust
VR20 = Final TX Bias (2)
VR21 = Transmit Frequency Adjust
VR803 = Power Range Adjust

Receive Adjust = L1, L2, L3, L4, L5, L6, L7, L8, L10, L11, L12
Transmit Adjust = L44, L43, L42, L40, L33, L31 (Spreadable Coil)

RCI 2990 (EPT 295013Z Board)

VR1 = AM "S" Meter
VR2 = SSB/CW "S" Meter
VR3 = SSB Squelch Range
VR4 = AM Squelch Range

VR7 = Carrier Balance
VR8 = RF Transmit Meter
VR11 = Driver TX Bias Adjust
VR12 = ALC SSB Power

VR13 = AM High Power Adjust
VR14 = AM Modulation AMC Adjust
VR15 = CW Level Adjust
VR16 = AM Low Power Adjust
VR21 = FM Deviation Adjust

Receive Adjust = L9, L11, L12, L13, L14, L3, L4, L5, L6
Transmit Adjust = L46, L47, L48, L43, L34

VARIABLE ALIGNMENTS SECTION

UNIDEN® RADIOS

PC76 XLW (New model w/Weather Channel Alert)

VR1 = IF Gain Adjust

VR2 = Squelch Range Adjust

VR3 = RX "S" Meter Adjust

VR4 = Modulation AMC adjust

VR5 = TX Meter Adjust

VR6 = Antenna Warning Adjust

Receive Adjust = L1, L2, L3, L4, L5, L6, L7, L8, L9

Transmit Adjust = L20, L21, L17, L16, L14, L13 (Spreadable) L12 (Spreadable)

PC122XL

VR1 = RX "S" Meter Adjust

VR2 = Squelch Adjust

VR3 = Transmit Frequency Adjust

VR4 = SSB Carrier Balance

VR5 = Modulation AMC adjust

VR6 = SSB RX "S" Meter Adjust

VR7 = TX Meter Adjust

VR8 = Final Bias Adjust

VR9 = Driver Bias Adjust

VR10 = AM Power Adjust

Receive Adjust = L-3, L-4, L-5, L-6, L-7, L-8, L-10, L11

Transmit Adjust = L-35, L-36, L-37, L-34, L-26, L-25

PRO501XL

VR1 = Squelch Range Adjust

Receive Adjust = L103, L102

Transmit Adjust = L3, L4, L5



SPECIAL INSTRUCTIONS

In the next few pages we have listed some of the more popular radios and their associated mike hookups. In column #1 we have listed the Radio Make & Model. In column #2 we have listed the radios' normal mike pin-out information. The balance of the columns list specific microphones and their wire *Color Codes* and how they are to be wired to each of the radios listed in column #1.

Although we have tried to cover the more popular mikes we realize that many more exist. This is why we listed in column #2 the pin-out information on each radio. With this information you should be able to wire any mike to any radio, as long as you know what each wires function is for the microphone.

Some listed microphones may require a special hookup modification in order to function properly. These are covered by footnotes in the radio or the microphone column. Some microphones may also require a resistor in the audio lead in order to eliminate feed back during receive and/or to reduce the DC potential on the audio lead. This is often required for some of the Midland and Kraco 4-Pin Models. Adding a resistor (47k to 270k) in series with the audio lead will usually eliminate any feedback. If you use an external PA speaker on these models you will need to use a 6 wire microphone instead of a 4 wire model.

Mike Type	Standard	ASTATIC	ASTATIC	SADELTA	GALAXY	TURNER	GALAXY	DAIWA
Model	MIKE	MIKE	MIKE	MIKE	MIKE	MIKE	MIKE	MIKE
	WRITING	WRITING	WRITING	WRITING	WRITING	WRITING	WRITING	WRITING
	HOOKUP	HOOKUP	HOOKUP	HOOKUP	HOOKUP	HOOKUP	HOOKUP	HOOKUP
	Color Code	Color Code	Color Code	Color Code	Color Code	Color Code	Color Code	Color Code
ALAN 555	1-Shield 2-Audio 3-Transmit 4-Receive Electronic	575M-6, 63GL, D104Ms, M4B 1104C & CM T-UIG, T-UP9 Duncoed Eagle Golden Eagle Night Eagle, K Silver Eagle, K Road Devil White-Audio Shield-Ground Red-Transmit Black-Receive Blue-Common Yellow-Audio Sw.	575M D104M T-UIG Standard VALOR PDC56 / Liche	Bravo Plus Echomaster + Echomaster Pro ME-3 MB-4 /R, Beep	DC-5215 (4 Wire)	Expander 500 Road King 56 RK 76	CB-660E1 CB-660E1R	EM-500 COBRA CA-70 CA-71 CA-72 CA-79 CA-80
ALAN 560	1-Shield 2-Audio 3-Transmit 4-Receive 5-Ch. Ctrl Up 6-Ch. Ctrl. Dn	1-Shield & Blue 2-White 3-Red 4-Black 5-NC 6-NC Yellow-NC	1-Shield 2-White 3-Red 4-Black 5-NC 6-NC	1-Shield 2-White 3-Brown 4-Green 5-NC 6-NC	1-Shield 2-Yellow 3-Red 4-Black	1-Shield & Red 2-White 3-Blue 4-Black 5-NC Yellow-NC	1-Sh & Black 2-White 3-Red 4-Blue 5-NC 6-NC	1-Sh & Black 2-Red 3-White 4-Blue 5-NC 6-NC
ROMAN CB-515, CB-525 CB-535, CB-710 CB-910 CB-920, CB-930 CB-950, CB-970 CB-990	1-Audio 2-Shield 3-Receive 4-Transmit	1-White 2-Shield & Blue 3-Black 4-Red Yellow-NC	1-White 2-Shield 3-Black 4-Red	1-White 2-Shield 3-Green 4-Brown	1-Yellow 2-Shield 3-Black 4-Red	1-White 2-Shield & Red 3-Black 4-Blue Yellow-NC	1-White 2-Sh & Black 3-Blue 4-Red	1-Red 2-Sh & Black 3-Blue 4-White
Correction to Volume 5 below for 18 ULTRA & 19ULTRA								
COBRA 18ULTRA 21, 77X, 78X 18LTD 19 19DX LTD 19LTD, 19GTL 21XLR, 26 21GTL, LTD 21LTD Classic 25GTL, LTD 25LTD-Classic Gold 25LTD WX Classic 25PLUS 29, 29XLR 29LTD, Classic 29LTD-Classic Gold 29LTD WX Classic 29PLUS 31PLUS, 33PLUS 40X 40XLR 47GTL, CAM89 49XLR, 49GTL 50LTD WX 135, 135XLR 138XLR 139XLR 146GTL 148GTL-DX 148GTL-B 1600GTL	1-Shield 2-Audio 3-Transmit 4-Receive Electronic	1-Shield & Blue 2-White 3-Red 4-Black Yellow-NC	1-Shield 2-White 3-Red 4-Black Electronic	1-Shield 2-White 3-Red 4-Green	1-Shield 2-Yellow 3-Red 4-Black	1-Shield & Red 2-White 3-Blue 4-Black Yellow-NC	1-Sh & Black 2-White 3-Red 4-Blue	1-Sh & Black 2-Red 3-Blue 4-Blue
COBRA 18V 18L, 19PLUS 20LTD 20PLUS 23PLUS 41PLUS	1-Audio 4-Shield 3-Transmit 4-Receive 3-NC	1-White 4-Sh & Blue 2-Red 4-Black 3-NC Yellow-NC	1-White 4-Shield 2-Red 3-Black 3-NC Electronic	1-White 2-Brown 3-Green 3-NC	1-Yellow 4-Shield 2-Red 3-Black 5-Black 5-NC	1-White 4-Shield & Red 2-Blue 3-Black 3-NC Yellow-NC	1-White 4-Sh & Black 2-Red 3-Blue 3-NC	1-Red 4-Sh & Black 2-White 5-Blue 3-NC

Mike Type	Standard	ASTATIC	ASTATIC	SADELTA	GALAXY	TURNER	GALAXY	DAIWA
Model	Mike Wiring HOOKUP	575M-6, 616L, D104M, 6MB 1104C & CM T-UGR, T-1 PB Diamond Eagle Golden Eagle Night Eagle, K Silver Eagle, K Road Devil	971M D104M T-UGR Stand VALOR PDC56 / Jumbo	Bravo Plus Echomaster + Echomaster Pro MB-3 MB-4 R. Beep	DC-5215 (4 Wire)	Expander 500 Road King 56 RK 76	CB-662E1 CB-6601R	EM-500 <u>COBRA</u> CA-70 CA-71 CA-72 CA-79 CA-80
		Color Code	Color Code	Color Code	Color Code	Color Code	Color Code	Color Code
		White-Audio Shield-Ground Red-Transmit Black-Receive Blue-Common Yellow-Audio Sw	White-Audio Shield-Ground Red-Transmit Black-Receive	White-Audio Shield-Ground Brown-Transmit Green-Receive	Yellow-Audio Shield-Ground Red-Transmit Black-Receive	White-Audio Shield-Ground Blue-Transmit Black-Receive Red-Common Yellow-Audio Sw	White-Audio Shield-Ground Red-Transmit Blue-Receive Black-Common	Red-Audio Shield-Ground White-Transmit Blue-Receive Black-Common
COBRA 94LTD 142GTL 142GTL 148GTL 148GTL 200GTL	1-Audio 2-Shield 3-Receive 4-Sw Wire 5-Transmit	1-White 2-Shield 3-Black 4-Blue 5-Red Yellow-NC	1-White 2-NC 3-Black 4-Shield 5-Red	1-White 2-NC 3-Green 4-Shield 5-Brown	1-Yellow 2-NC 3-Black 4-Shield 5-Red	1-White 2-Shield 3-Black 4-Red 5-Blue Yellow-NC	1-White 2-Shield 3-Blue 4-Black 5-Red	1-Red 2-Shield 3-Blue 4-Black 5-White
COLT 210 220 222 510	1-Audio 4-NC 2-Transmit 5-Receive 3-Shield	1-White 4-NC 2-Red 3-Black 3-Shield & Blue Yellow-NC	1-White 4-NC 2-Red 3-Green 3-Shield Electronic	1-White 4-NC 2-Brown 3-Green 3-Shield	1-Yellow 4-NC 2-Red 3-Black 3-Shield	1-White 4-NC 2-Blue 3-Black 3-Shield & Red Yellow-NC	1-White 4-NC 2-Red 3-Black 3-Sh & Black	1-Red 4-NC 2-White 3-Blue 3-Sh & Black
COLT 250 290 480 485 800 870 1000 1200 2400	1-Audio 2-Shield 3-Receive 4-Transmit	1-White 2-Shield & Blue 3-Black 4-Red Yellow-NC	1-White 2-Shield 3-Green 4-Red Electronic	1-White 2-Shield 3-Black 4-Brown 4-Red	1-Yellow 2-Shield 3-Black 4-Blue 4-Red	1-White 2-Shield & Red 3-Black 4-Blue Yellow-NC	1-White 2-Sh & Black 3-Blue 4-Red Yellow-NC	1-Red 2-Sh & Black 3-Blue 4-White
COMMTRON CCX XII	1-Audio 4-NC 2-Transmit 5-Receive 3-Shield	1-White 4-NC 2-Red 5-Black 3-Shield & Blue Yellow-NC	1-White 4-NC 2-Red 5-Green 3-Shield Electronic	1-White 4-NC 2-Brown 5-Green 3-Shield	1-Yellow 4-NC 2-Red 3-Black 3-Shield	1-White 4-NC 2-Blue 3-Black 3-Shield & Red Yellow-NC	1-White 4-NC 2-Blue 5-Blue 3-Sh & Black	1-Red 4-NC 2-White 5-Blue 3-Sh & Black
CONNEX 1300	1-Shield 2-Audio 3-Transmit 4-Receive Electronic	1-Sh & Blue 2-White 3-Red 4-Black Yellow-NC	1-Shield 2-White 3-Red 4-Black Electronic	1-Shield 2-Yellow 3-Brown 4-Green	1-Shield 2-Yellow 3-Red 4-Black	1-Shield & Red 2-White 3-Blue 4-Black Yellow-NC	1-Sh & Black 2-White 3-Red 4-Blue	1-Sh & Black 2-Red 3-White 4-Blue
COURIER Galaxy	1-Audio 2-Shield 3-Receive 4-Sw. Wire 5-Transmit	1-White 2-Shield 3-Black 4-Blue 5-Red Yellow-NC	1-White 2-NC 3-Black 4-Shield 5-Red	1-White 2-NC 3-Green 4-Shield 5-Brown	1-Yellow 2-NC 3-Black 4-Shield 5-Red	1-White 2-Shield 3-Blue 4-Red 5-Red Yellow-NC	1-White 2-Shield 3-Blue 4-Black 5-Red	1-Red 2-Shield 3-Blue 4-Black 5-White
CRAIG L131	1-NC 2-Audio 3-Receive 4-Shield 5-Transmit	1-NC 2-White 3-Black 4-Shield & Blue 5-Red	1-NC 2-White 3-Black 4-Shield 5-Red	1-NC 2-White 3-Green 4-Shield 5-Brown	1-NC 2-Yellow 3-Black 4-Shield 5-Red	1-NC 2-White 3-Blue 4-Shield & Red 5-Red	1-NC 2-White 3-Blue 4-Sh & Black 5-Red	1-NC 2-Red 3-Blue 4-Sh & Black 5-White
CRAIG L-232	1-Audio 2-Shield 3-Receive 4-Switch Wire 5-Transmit	1-White 2-Shield 3-Black 4-Blue 5-Red Yellow-NC	1-White 2-NC 3-Black 4-Shield 5-Red	1-White 2-NC 3-Green 4-Shield 5-Brown	1-Yellow 2-NC 3-Black 4-Shield 5-Red	1-White 2-Shield 3-Black 4-Red 5-Blue Yellow-NC	1-White 2-Shield 3-Blue 4-Black 5-Red	1-Red 2-Shield 3-Blue 4-Black 5-White
CRAIG 4101, 4102 4201 L101 L102 L231 L331	1-NC 2-Audio 3-Shield 4-Receive 5-Transmit	1-NC 2-White 3-Shield & Blue 4-Black 5-Red Yellow-NC	1-NC 2-White 3-Shield 4-Black 5-Red Electronic	1-NC 2-White 3-Shield 4-Green 5-Brown	1-NC 2-White 3-Shield 4-Black 5-Red	1-NC 2-White 3-Shield & Red 4-Black 5-Blue Yellow-NC	1-NC 2-White 3-Sh & Black 4-Blue 5-Red	1-NC 2-Red 3-Sh & Black 4-Blue 5-White

Mike Type	Standard	ASTATIC 3738A-5, 636L D10484, M68L 1104C & CM T-UGP, T-UP9 Diamond Eagle Golden Eagle Night Eagle, K Silver Eagle, K Road Devil	ASTATIC 3738M D1048M T-UGB Stand VALOR PDC66 / Echo	SADELTA Bravo Plus Echomaster 4 Echomaster Pro ME-3 MB-4 R. Bmp	GALAXY DC-521S (4 Wts)	TURNER Expander 500 Road King 36 RK 76	GALAXY CB-660E1 CB-660E1R	DAIWA EM-500 CODRA CA-70 CA-71 CA-72 CA-79 CA-80
Model	HOOKUP	Color Code White-Audio Shield-Ground Red-Transmit Black-Receive Blue-Common Yellow-Audio Sw	Color Code White-Audio Shield-Ground Red-Transmit Black-Receive	Color Code White-Audio Shield-Ground Brown-Transmit Green-Receive	Color Code Yellow-Audio Shield-Ground Red-Transmit Black-Receive	Color Code White-Audio Shield-Ground Blue-Transmit Black-Receive Red-Common Yellow-Audio Sw	Color Code White-Audio Shield-Ground Red-Transmit Blue-Receive Black-Common	Color Code Red-Audio Shield-Ground White-Transmit Blue-Receive Black-Common
CRAIG L103 L104	1-Shield 2-Audio 3-Transmit 4-Receive Electronic	1-Sh & Blue 2-White 3-Red 4-Black Yellow-NC	1-Shield 2-White 3-Red 4-Black Electronic	1-Shield 2-White 3-Red 4-Green	1-Shield 2-Yellow 3-Red 4-Black	1-Shield & Red 2-White 3-Red 4-Black Yellow-NC	1-Sh & Black 2-White 3-Red 4-Blue	1-Sh & Black 2-Red 3-White 4-Blue
DURLAND SS-1000B	1-Shield 2-Audio 3-Transmit 4-Receive Electronic	1-Shield & Blue 2-White 3-Red 4-Black Yellow-NC	1-Shield 2-White 3-Red 4-Black Electronic	1-Shield 2-White 3-Brown 4-Green	1-Shield 2-Yellow 3-Red 4-Black	1-Shield & Red 2-White 3-Red 4-Black Yellow-NC	1-Sh & Black 2-White 3-Red 4-Blue	1-Sh & Black 2-Red 3-White 4-Blue
EAGLE EAGLE 2000	1-Shield 2-Audio 3-Transmit 4-Receive Electronic	1-Shield & Blue 2-White 3-Red 4-Black Yellow-NC	1-Shield 2-White 3-Red 4-Black Electronic	1-Shield 2-White 3-Brown 4-Green	1-Shield 2-Yellow 3-Red 4-Black	1-Shield & Red 2-White 3-Red 4-Black Yellow-NC	1-Sh & Black 2-White 3-Red 4-Blue	1-Sh & Black 2-Red 3-White 4-Blue
EAGLE EAGLE 5000	1-Shield 2-Audio 3-Transmit 4-Receive 5-Ch Cut Up 6-Ch Cut Dn	1-Shield & Blue 2-White 3-Red 4-Black 5-NC 6-NC Yellow-NC	1-Shield 2-White 3-Red 4-Black 5-NC 6-NC	1-Shield 2-White 3-Brown 4-Green 5-NC 6-NC	1-Shield 2-Yellow 3-Red 4-Black 5-NC 6-NC	1-Shield & Red 2-White 3-Blue 4-Black 5-NC 6-NC Yellow-NC	1-Sh & Black 2-White 3-Red 4-Blue 5-NC 6-NC	1-Sh & Black 2-Red 3-White 4-Blue 5-NC 6-NC
EMPEROR TS-5010	1-Audio 2-Shield 3-Transmit 4-Ch Cut Up 5-Ch Cut Dn	1-White 2-Shield & Blue 3-Red 4-NC 5-NC Yellow-NC Black-NC	1-White 2-Shield 3-Red 4-NC 5-NC Black-NC	1-White 2-Shield 3-Brown 4-NC 5-NC Green-NC	1-Yellow 2-Shield 3-Red 4-NC 5-NC Black-NC	1-White 2-Sh & Red 3-Blue 4-NC 5-NC Yellow-NC Black-NC	1-White 2-Sh & Black 3-Red 4-NC 5-NC Yellow-NC Blue-NC	1-Red 2-Sh & Black 3-White 4-NC 5-NC Blue-NC
FORMAC 400 700	1-Audio 2-Shield 3-Receive 4-Transmit	1-White 2-Shield & Blue 3-Black 4-Red Yellow-NC	1-White 2-Shield 3-Black 4-Red	1-White 2-Shield 3-Green 4-Brown	1-Yellow 2-Shield 3-Black 4-Red	1-White 2-Shield & Red 3-Black 4-Blue Yellow-NC	1-White 2-Sh & Black 3-Blue 4-Red	1-Red 2-Sh & Black 3-Blue 4-White
GALAXY 2100 J1 PLUS DX 34HML DX 44V DX 55V DX 66V DX 77HML DX 7TV DX 88HML DX99V JUPITER MARKS MIRAGE MIRAGE 44 MIRAGE88 PLUTO SATURN SATURN II SIRIUS SUPER GALAXY	1-Shield 2-Audio 3-Transmit 4-Receive Electronic	1-Shield & Blue 2-White 3-Red 4-Black Yellow-NC	1-Shield 2-White 3-Red 4-Black Electronic	1-Shield 2-White 3-Brown 4-Green	1-Shield 2-Yellow 3-Red 4-Black	1-Shield & Red 2-White 3-Blue 4-Black Yellow-NC	1-Sh & Black 2-White 3-Red 4-Blue	1-Sh & Black 2-Red 3-White 4-Blue

Mike Type	ASTATIC	ASTATIC	SADELTA	GALAXY	TURNER	GALAXY	DAIWA	
	<i>Standard</i>	575M-6, 636L, D104M, M6B 1104C & CM T-10D, T-1DP Diamond Eagle Golden Eagle Night Eagle, K Silver Eagle, K Road Devil	575M D104M T-U8H Stand VALOR PDC66 / Echo	Brown Plus Echomaster + Echomaster Pro ME-3 MB-4/R, Bsp	DC-321B (+ Wcc)	Expander 500 Road King 56 RK 76	CB-660E1 CB-660E1R	
	<i>Mike</i>						<u>COBRA</u>	
	<i>Wiring</i>						CA-70 CA-71 CA-72 CA-79 CA-80	
Model	HOOKUP	<i>Color Code</i> White-Audio Shield-Ground Red-Transmit Black-Receive Blue-Common Yellow-Audio Sw	<i>Color Code</i> White-Audio Shield-Ground Red-Transmit Black-Receive	<i>Color Code</i> White-Audio Shield-Ground Brown-Transmit Green-Receive	<i>Color Code</i> Yellow-Audio Shield-Ground Red-Transmit Black-Receive	<i>Color Code</i> White-Audio Shield-Ground Blue-Transmit Black-Receive Red-Common Yellow-Audio Sw	<i>Color Code</i> White-Audio Shield-Ground Red-Transmit Blue-Receive Black-Common	<i>Color Code</i> Red-Audio Shield-Ground White-Transmit Blue-Receive Black-Common
GALAXY SATURN TURBO	1-Shield 2-Audio 3-Transmit 4-Receive 5-Ch Cut Up 6-Ch Cut Dn	1-Shield & Blue 2-White 3-Red 4-Black 5-NC 6-NC Yellow-NC	1-Shield 2-White 3-Red 4-Black 5-NC 6-NC	1-Shield 2-White 3-Brown 4-Green 5-NC 6-NC	1-Shield 2-Yellow 3-Red 4-Black 5-NC 6-NC	1-Shield & Red 2-White 3-Red 4-Black 5-NC 6-NC Yellow-NC	1-Sh & Black 2-White 3-Red 4-Blue 5-NC 6-NC	
G.E. 3-5800, 3-5801A 3-5804B, G 3-5806, 3-5806A 3-5808A 3-5809, 3-5809B 3-5809C 3-5810A, B, 3-5811B 3-5818A 3-5871, 3-5871A, B	4-Audio 1-Shield 2-NC 3-Transmit 3-Receive	4-White 1-Shield & Blue 2-NC 3-Red 5-Black Yellow-NC	Not Comp 4-White 1-Shield 2-NC 3-Red 5-Black Electronic	Not Comp 4-White 1-Shield 2-NC 3-Brown 5-Green	Not Comp 4-Yellow 1-Shield 2-NC 3-Red 5-Black	4-White 1-Shield & Red 2-NC 3-Red 5-Black Yellow-NC	4-White 1-Sh & Black 2-NC 3-Red 5-Blue	4-Red 1-Sh & Black 2-NC 3-White 4-Blue 5-NC 6-NC
G.E. 3-5802, 3-5804D 3-5812A 3-5813, A, B 3-5814, A, B 3-5817A, 3-5818 3-5819A, 3-5823, A 3-5869, A 3-5873, 3-5875A	1-Audio 2-Shield 3-Receive 4-Transmit	1-White 2-Shield & Blue 3-Black 4-Red Yellow-NC	Not Comp 1-White 2-Shield 3-Black 4-Red *Add a 47k resistor in series with the white lead.	Not Comp. 1-White 2-Shield 3-Green 4-Brown	Not Comp. 1-Yellow 2-Shield 3-Black 4-Red	1-White 2-Shield & Red 3-Black 4-Blue Yellow-NC	1-White 2-Sh & Black 3-Blue 4-Red	1-Red 2-White 3-Blue 4-White
K-40 Production Model #1 Production Model #2 Production Model #3 Production Model #6	1-Audio 2-Shield 3-Receive 4-Transmit	1-White 2-Shield & Blue 3-Black 4-Red Yellow-NC	1-White 2-Shield 3-Black 4-Red	1-White 2-Shield 3-Green 4-Brown	1-Yellow 2-Shield 3-Black 4-Red	1-White 2-Shield & Red 3-Black 4-Blue Yellow-NC	1-White 2-Sh & Black 3-Blue 4-Red	1-Red 2-Sh & Black 3-Blue 4-White
KRACO 2310, 2320, 2330 2345, 2355 2320A, 2330B KCB-4001, 4005 KCB-4010, 4020 KCB-4030, 4045	1-Audio 2-Shield 3-Receive 4-Transmit	1-White 2-Shield & Blue 3-Black 4-Red Yellow-NC	1-White 2-Shield 3-Black 4-Red	1-White 2-Shield 3-Green 4-Brown	1-Yellow 2-Shield 3-Black 4-Red	1-White 2-Shield & Red 3-Black 4-Blue Yellow-NC	1-White 2-Sh & Black 3-Blue 4-Red	1-Red 2-Sh & Black 3-Blue 4-White
LAFAYETTE TELSAT SSB-140	1-Audio 2-Transmit 3-Switch Wire 4-Shield 5-Receive	1-White 2-Red 3-Blue 4-Shield 5-Black Yellow-NC	1-White 2-Red 3-Shield 4-NC 5-Black	1-White 2-Brown 3-NC 4-NC 5-Green	1-Yellow 2-Red 3-Shield 4-NC 5-Black	1-White 2-Blue 3-Red 4-NC 5-Black Yellow-NC	1-White 2-Red 3-Black 4-Shield 5-Blue	1-Red 2-White 3-Black 4-Shield 5-Blue
MAJOR M-120	1-Audio 2-Shield 3-Receive 4-Transmit	1-White 2-Shield & Blue 3-Black 4-Red Yellow-NC	1-White 2-Shield 3-Black 4-Red	1-White 2-Shield 3-Green 4-Brown	1-Yellow 2-Shield 3-Black 4-Red	1-White 2-Shield & Red 3-Black 4-Blue Yellow-NC	1-White 2-Sh & Black 3-Blue 4-Red	1-Red 2-Sh & Black 3-Blue 4-White
MAXON MCB-60	1-Shield 2-Audio 3-Transmit 4-Receive Electronic	1-Shield & Blue 2-White 3-Red 4-Black Yellow-NC	1-Shield 2-White 3-Red 4-Black Electronic	1-Shield 2-White 3-Brown 4-Green	1-Shield 2-Yellow 3-Red 4-Black	1-Shield & Red 2-Yellow 3-Red 4-Black Yellow-NC	1-Sh & Black 2-White 3-Red 4-Blue	1-Sh & Black 2-Red 3-White 4-Blue

Mike Type	Standard	ASTATIC	ASTATIC	SADELTA	GALAXY	TURNER	GALAXY	DAIWA
Model	MIKE	Color Code	Color Code	Color Code	Color Code	Color Code	Color Code	Color Code
	MIKE	573MG, GME D104M, MGB 1104C & CM T-DQ9, T-UP9 Diamond Eagle Golden Eagle Night Eagle, K Silver Eagle, K Red Devil	573M D104M T-UGR Stand VALOR PDC66 / Echo	Brono Flat Echomaster 4 Echomaster Pro ME-3 MB-4 / B, Bsp	DC-5215 (4 Wire)	Expander 500 Road King 56 RK76	CB-660E1 CB-660E2	EM-500 COBRA CA-70 CA-71 CA-72 CA-79 CA-80
	HOOKUP	White-Audio Shield-Ground Red-Transmit Black-Receive Blue-Common Yellow-Audio Sw	White-Audio Shield-Ground Red-Transmit Black-Receive	White-Audio Shield-Ground Brown-Transmit Green-Receive	Yellow-Audio Shield-Ground Red-Transmit Black-Receive	White-Audio Shield-Ground Blue-Transmit Black-Receive Yellow-Audio Sw	White-Audio Shield-Ground Red-Transmit Blue-Receive Black-Common	Red-Audio Shield-Ground White-Transmit Blue-Receive Black-Common
MIDLAND 151M 77-092 77-094 77-099 77-102, 77-104 77-103, 77-106 77-116 77-118	1-Audio 4-Shield 2-Transmit 5-Receive 3-NC	1-White 4-Sh & Blue 2-Red 5-Black 3-NC Yellow-NC	1-White 4-Shield 2-Red 5-Black 3-NC Electronic	1-White 4-Shield 2-Brown 5-Green 3-NC	1-Yellow 4-Shield 2-Red 5-Black 3-NC	1-White 4-Shield & Red 2-Blue 5-Black 3-NC Yellow-NC	1-White 4-Sh & Black 2-Red 5-Blue 3-NC	1-Red 4-Sh & Black 2-White 5-Blue 3-NC
MIDLAND 77-104XL	1-Audio 2-Shield 3-Receive 4-Transmit	1-White 2-Shield & Blue 3-Black 4-Red Yellow-NC	1-White 2-Shield 3-Black 4-Red	1-White 2-Shield 3-Green 4-Brown	1-Yellow 2-Shield 3-Black 4-Red	1-White 2-Shield & Red 3-Black 4-Blue Yellow-NC	1-White 2-Sh & Black 3-Blue 4-Red	1-Red 2-Sh & Black 3-Blue 4-White
NATO 2050	1-Audio 2-Shield 3-Receive 4-Transmit	1-White 2-Shield & Blue 3-Black 4-Red Yellow-NC	1-White 2-Shield 3-Black 4-Red	1-White 2-Shield 3-Green 4-Brown	1-Yellow 2-Shield 3-Black 4-Red	1-White 3-Shield & Red 3-Black 4-Blue Yellow-NC	1-White 2-Sh & Black 3-Blue 4-Red	1-Red 2-Sh & Black 3-Blue 4-White
PAL ELECTRONICS Coyote Roadrunner	1-Audio 2-Transmit 3-Receive 4-Shield Relay or Electronic	1-White 2-Red 3-Blue 4-Shield Yellow-NC Black-NC	1-White 2-Red 3-Black 4-Shield	1-White 2-Brown 3-Green 4-Shield	1-Yellow 2-Red 3-Black 4-Shield	1-White 2-Blue 3-Black 4-Shield Yellow-NC Black-NC	1-White 2-Red 3-Black 4-Shield Blue-NC	1-Red 2-White 3-Black 4-Shield Blue-NC
PALOMAR 2400	1-Audio 2-Shield 3-Receive 4-Transmit	1-White 2-Shield & Blue 3-Black 4-Red Yellow-NC	1-White 2-Shield 3-Black 4-Red	1-White 2-Shield 3-Green 4-Brown	1-Yellow 2-Shield 3-Black 4-Red	1-White 2-Shield & Red 3-Black 4-Blue Yellow-NC	1-White 2-Sh & Black 3-Blue 4-Red	1-Red 2-Sh & Black 3-Blue 4-White
PARADYNAMICS PDC-19 PDC-25 PDC-29	1-Audio 2-Shield 3-Receive 4-Transmit	1-White 2-Shield & Blue 3-Black 4-Red Yellow-NC	1-White 2-Shield 3-Black 4-Red	1-White 2-Shield 3-Green 4-Brown	1-Yellow 2-Shield 3-Black 4-Blue	1-White 2-Shield & Red 3-Black 4-Blue Yellow-NC	1-White 2-Sh & Black 3-Blue 4-Red	1-Red 2-Sh & Black 3-Blue 4-Red
PYRAMID CB-24 CB-24 CB-25 CB-26 CB-28	1-Audio 2-Shield 3-Receive 4-Transmit	1-White 2-Shield & Blue 3-Black 4-Red Yellow-NC	1-White 2-Shield 3-Black 4-Red	1-White 2-Shield 3-Green 4-Brown	1-Yellow 2-Shield 3-Black 4-Red Yellow-NC	1-White 2-Shield & Red 3-Blue 4-Blue Yellow-NC	1-White 2-Sh & Black 3-Blue 4-Red	1-Red 2-Sh & Black 3-Blue 4-White
PYRAMID 1100	1-Shield 2-Audio 3-Transmit 4-Receive Electronic	1-Sh & Blue 2-White 3-Red 4-Black Yellow-NC	1-Shield 2-White 3-Red 4-Black Electronic	1-Shield 2-White 3-Brown 4-Green	1-Shield 2-White 3-Red 4-Black Yellow-NC	1-Shield & Red 2-White 3-Blue 4-Black Yellow-NC	1-Sh & Black 2-White 3-Red 4-Blue	1-Sh & Black 2-Red 3-White 4-Blue
RANGER RCI-2080	1-Shield 2-Audio 3-Transmit 4-Receive	1-Shield & Blue 2-White 3-Red 4-Black Yellow-NC	1-Shield 2-White 3-Red 4-Black	1-Shield 2-White 3-Brown 4-Green	1-Shield 2-White 3-Red 4-Black	1-Shield & Red 2-White 3-Blue 4-Black Yellow-NC	1-Sh & Black 2-White 3-Red 4-Blue	1-Sh & Black 2-Red 3-White 4-Blue

Mike Type	Standard	ASTATIC	ASTATIC	SADELTA	GALAXY	TURNER	GALAXY	DAIWA
Model	Wiring HOOKUP	Color Code	Color Code	Color Code	Color Code	Color Code	Color Code	Color Code
	<i>Mike</i> <i>Wiring</i> <i>HOOKUP</i>	575M-G, 636L, D104M, M8B 1104E & CM T-UGP, T-UP9 Diamond Eagle Golden Eagle Night Eagle, K Silver Eagle, K Road Devil	575M D104M T-UGP Stand VALOR PDC66 / Edzo	Brown Plus EchoMaster + EchoMaster Pro ME-3 MB-4/R, Beep	DC-5215 (a w/e)	Expander 500 Road King 56 RK 76	CB-660E1 CB-660E1R	EM-500 <u>COBRA</u> CA-70 CA-71 CA-72 CA-79 CA-80
		White-Audio Shield-Ground Red-Transmit Black-Receive Blue-Common Yellow-Audio Sw	White-Audio Shield-Ground Red-Transmit Black-Receive	White-Audio Shield-Ground Brown-Transmit Green-Receive	White-Audio Shield-Ground Red-Transmit Black-Receive	White-Audio Shield-Ground Blue-Transmit Black-Receive Red-Common Yellow-Audio Sw	White-Audio Shield-Ground Red-Transmit Blue-Receive Black-Common	Red-Audio Shield-Ground White-Terminal Blue-Receive Black-Common
RANGER RC1-2900 RC1-2950 RC1-2970 RC1-2990	1-Shield 2-Audio 3-Transmit 4-Receive 5-Ch Cntl Up 6-Ch Cntl Dn	1-Shield & Blue 2-White 3-Red 4-Black 5-NC 6-NC Yellow-NC	1-Shield 2-White 3-Red 4-Black 5-NC 6-NC	1-Shield 2-White 3-Brown 4-Green 5-NC 6-NC	1-Shield 2-Yellow 3-Red 4-Black 5-NC 6-NC	1-Shield & Red 2-White 3-Blue 4-Black 5-NC 6-NC Yellow-NC	1-SB & Black 2-White 3-Red 4-Blue 5-NC 6-NC	1-SB & Black 2-Red 3-White 4-Blue 5-NC 6-NC
RANGER ST-1000 / HCAR18	4-NC 1-Audio 2-Shield 3-Receive 3-Transmit	4-NC 1-White 2-Shield & Blue 3-Black 3-Red Yellow-NC	4-NC 1-White 2-Shield 5-Black 3-Red	4-NC 1-White 2-Shield 5-Green 3-Brown	4-NC 1-Yellow 2-Shield 5-Black 3-Red	4-NC 1-White 2-Shield & Red 5-Black 3-Blue Yellow-NC	4-NC 1-White 2-Shield & Black 5-Blue 3-Red	4-NC 1-White 2-Shield & Black 5-Blue 3-White
RANGER AR-3300	1-5 Radio Ctl 6-Transmit 7-Audio 8-Audio	1-5 NC 6-Red 7-Blue & Shield 8-White Yel & Black-NC	1-5 NC 6-Red 7-Shield 8-White Black-NC	1-5 NC 6-Blue 7-Shield 8-White Green-NC	1-5 NC 6-Red 7-Shield 8-Yellow Black-NC	1-5 NC 6-Blue 7-Shield & Red 8-White Yel & Black-NC	1-5 NC 6-Red 7-Black & Shield 8-White Yel & Blue-NC	1-5 NC 6-White 7-Black & Shield 8-Red Yel & Blue-NC
REALISTIC TRC-24A, 24B TRC-30, 30A TRC-55, 56, 57 TRC-67 TRC-410 TRC-411 TRC-412 TRC-413 TRC-414 TRC-415 TRC-417 TRC-420 TRC-421, 421A TRC-422A TRC-424 TRC-425 TRC-426 TRC-427 TRC-428 TRC-430 TRC-431, TRC-432 TRC-433, TRC-434 TRC-440, TRC-441 TRC-448, TRC-449 TRC-450, TRC-451 TRC-452, TRC-453 TRC-454, TRC-455 TRC-456, TRC-457 TRC-458 TRC-459 TRC-460 TRC-461 TRC-462 TRC-466 TRC-467 TRC-468 TRC-469 TRC-470 TRC-473 TRC-477 TRC-479 TRC-480 TRC-482 TRC-490 TRC-492 TRC-500	4-Audio 1-Shield 2-NC 3-Receive 3-Transmit	4-White 1-Shield & Blue 2-NC 5-Black 3-Receive Yellow-NC	4-White 1-Shield 2-NC 5-Black 3-Red	4-White 1-Shield 2-NC 5-Green 3-Brown	4-Yellow 1-Shield 2-NC 5-Black 3-Red	4-White 1-Shield & Red 2-NC 5-Black 3-Red Yellow-NC	4-White 1-SB & Black 2-NC 5-Blue 3-Red	4-Red 1-SB & Black 2-NC 5-Blue 3-White

Mike Type	Standard	ASTATIC 575M-6, 6ML D104M, M6B 1104C & CM	ASTATIC 575M D104M T-10G Stand	SADELTA Bravo Plus Edmaster + Edmaster Pro	GALAXY DC-3215 (4-Wire)	TURNER Exquisite 500 Road King 56 RK 76	GALAXY CB-660E1 CB-660E1R	DAIWA EM-500
Model	MIKE Wiring HOOKUP	Color Code White-Audio Shield-Ground Red-Transmit Black-Receive Blue-Common Yellow-Audio Sw	Color Code White-Audio Shield-Ground Red-Transmit Black-Receive	Color Code White-Audio Shield-Ground Brown-Transmit Green-Receive	Color Code Yellow-Audio Shield-Ground Red-Transmit Black-Receive	Color Code White-Audio Shield-Ground Blue-Transmit Black-Receive Red-Common Yellow-Audio Sw	Color Code White-Audio Shield-Ground Red-Transmit Blue-Receive Black-Common	COBRA CA-70 CA-71 CA-72 CA-79 CA-80
ROBYN AM-500P* WV-110 WV-23 WV-23A SX-007 DG-30 DG-130D LB-23 LB-23A LB-120 007-140 * Add a 6J capacitor in series with the white lead.	1-Audio 2-Shield 3-Receive 4-Transmit Electronic	1-White 2-Shield & Blue 3-Black 4-Transmit Yellow-NC	1-White 2-Shield 3-Black 4-Red	1-White 2-Shield 3-Green 4-Brown	1-Yellow 2-Shield 3-Black 4-Red	1-White 2-Shield & Red 3-Blue 4-Blue Yellow-NC	1-White 2-Sh & Black 3-Blue 4-Red	1-Red 2-Sh & Black 3-Blue 4-White
ROBYN SB-510D* SB-520D* * Add a .01 capacitor in series with the white lead.	1-Audio 2-Shield 3-Transmit 4-Ground Electronic or Relay	1-White 2-Shield & Blue 3-Red 4-Black Yellow-NC	1-White 2-Shield 3-Red 4-Black	1-White 2-Shield 3-Brown 4-Green	1-Yellow 2-Shield 3-Black 4-Red	1-White 2-Shield & Red 3-Blue 4-Black Yellow-NC	1-White & Black 3-Red 4-Blue	1-Red 2-Shield & Black 3-White 4-Blue
SAGA 2530	1-Audio 2-Shield 3-Transmit 4-Receive	1-White 2-Shield & Blue 3-Red 4-Black Yellow-NC	1-White 2-Shield 3-Red 4-Black	1-White 2-Shield 3-Brown 4-Green	1-Yellow 2-Shield 3-Red 4-Black	1-White 2-Shield & Red 3-Blue 4-Black Yellow-NC	1-White 2-Sh & Black 3-Red 4-Blue	1-Red 2-Sh & Black 3-White 4-Blue
SCOTT DAK IX DAK X	1-Audio 2-Shield 3-Relay 4-Transmit	1-White 2-Shield 3-Blue 4-Red Black-NC Yellow-NC	1-White 2-Shield 3-Black 4-Red RELAY	1-White 2-Shield 3-Green 4-Brown	1-Yellow 2-Shield 3-Black 4-Red	1-White 2-Shield 3-Red 4-Blue Black-NC Yellow-NC	1-White 2-Shield 3-Black 4-Red Black-NC	1-Red 2-Shield 3-Black 4-White Black-NC
SCOTT Dak Mark II Dak Mark III Dak Mark V	1-Audio 4-Shield 2-Transmit 5-Receive 3-Transmit Sw	1-White 4-Shield 2-Red 5-Black 3-Blue Yellow-NC	1-White 4-NC 2-Red 5-Black 3-Shield	1-White 4-NC 2-Brown 5-Green 3-Shield	1-Yellow 4-NC 2-Red 5-Black 3-Shield	1-White 4-Shield 2-Blue 5-Black 3-Red Yellow-NC	1-White 4-Shield 2-Red 5-Blue 3-Black	1-Red 4-Shield 2-White 5-Blue 3-Black
SEARS 170.38050700 562.38200700 663.38000000 663.38020800 663.38070700 934.36710500 934.36712600 934.36748500 934.36741600 934.36742600 934.36756600 943.36735600 934.36771500 934.36772600 934.38060700 934.38062700 934.38080700 934.38081700 934.38110700 934.38120700 934.38260700 934.38270700 Roadliner(3822)	4-Audio 1-Shield 2-NC 5-Receive 3-Transmit	4-White 1-Shield & Blue 2-NC 5-Black 3-Red Yellow-NC	4-White 1-Shield 2-NC 5-Black 3-Red	4-White 1-Shield 2-NC 5-Green 3-Brown	4-Yellow 1-Shield 2-NC 5-Black 4-Red	4-White 1-Shield & Red 2-NC 5-Black 3-Blue Yellow-NC	4-White 1-Sh & Black 2-NC 5-Blue 3-Red	4-Red 1-Sh & Black 2-NC 5-Blue 3-White

Mike Type	Standard	ASTATIC	ASTATIC	SADELTA	GALAXY	TURNER	GALAXY	DAIWA
Model	Mike Wiring HOOKUP	575M-6, 636L D104M, M6B 1104C & CM T-UG9, T-UT9 Diamond Eagle Golden Eagle Night Eagle, K Silver Eagle, K Road Devil Color Code White-Audio Shield-Ground Red-Transmit Black-Receive Blue-Common Yellow-Audio Sw	575M D104M T-UG9 Stated VALOR PDC6 / Echo Color Code White-Audio Shield-Ground Red-Transmit Black-Receive	Bravo Plus Echomaster + Echomaster Pro ME-1 MB-4/R Deep Color Code White-Audio Shield-Ground Blue-Transmit Green-Receive	DC-5218 (4 Wcs) Color Code Yellow-Audio Shield-Ground Black-Receive	Expander 500 Road King 56 RK 76 Color Code White-Audio Shield-Ground Black-Receive Red-Common Yellow-Audio Sw	CB-660E1 CB-660EIR Color Code White-Audio Shield-Ground Red-Transmit Blue-Receive Black-Common	EM-500 COBRA CA-70 CA-71 CA-72 CA-79 CA-80 Color Code Red-Audio Shield-Ground White-Transmit Blue-Receive Black-Common
SOMMERKAMP TS-2050X	1-Shield 2-Audio 3-Transmit 4-Receive 5-Ch. Up 6-Ch. Down	1-Sh & Blue 2-White 3-Red 4-Black 5-NC 6-NC Yellow-NC	1-Shield 2-White 3-Red 4-Black 5-NC 6-NC	1-Shield 2-White 3-Brown 4-Green 5-NC 6-NC	1-Shield 2-Yellow 3-Red 4-Black 5-NC 6-NC	1-Shield & Red 2-White 3-Blue 4-Black Yellow-NC	1-Sh & Black 2-White 3-Red 4-Blue 5-NC 6-NC	1-Sh & Black 2-Red 3-White 4-Blue 5-NC 6-NC
STANDARD Horizon 29 Horizon 29A	1-Shield 2-Audio 3-Transmit 4-Receive	1-Shield & Blue 2-White 3-Red 4-Black Yellow-NC	1-Shield 2-White 3-Red 4-Black	1-Shield 2-White 3-Brown 4-Green	1-Shield 2-Yellow 3-Red 4-Black	1-Shield & Red 2-White 3-Blue 4-Black Yellow-NC	1-Sh & Black 2-White 3-Red 4-Blue	1-Sh & Black 2-Red 3-White 4-Blue
SUPERSTAR "GR" ~ "JA" ~ LBJ 105F 106F TEK-505D TEK-506D 120 121 1900	1-Shield 2-Audio 3-Transmit 4-Receive	1-Shield & Blue 2-White 3-Red 4-Black Yellow-NC	1-Shield 2-White 3-Red 4-Black	1-Shield 2-White 3-Brown 4-Green	1-Shield 2-Yellow 3-Red 4-Black	1-Shield & Red 2-White 3-Blue 4-Black Yellow-NC	1-Sh & Black 2-White 3-Red 4-Blue	1-Sh & Black 2-Red 3-White 4-Blue
SUPERSTAR 160FM	1-Audio 2-Shield 3-Receive 4-Sw. Wire 5-Transmit	1-White 2-Shield 3-Black 4-Blue 5-Red Yellow-NC	1-White 2-NC 3-Black 4-Shield 5-Red	1-White 2-NC 3-Green 4-Shield 5-Brown	1-Yellow 2-NC 3-Black 4-Shield 5-Red Yellow-NC	1-White 2-Shield 3-Blue 4-Red 5-Blue Yellow-NC	1-White 2-Shield 3-Blue 4-Black 5-Red	1-Red 2-Shield 3-Blue 4-Black 5-White
SUPERSTAR 2000	1-Audio 2-Shield 3-Receive 4-Transmit	1-White 2-Shield & Blue 3-Black 4-Red Yellow-NC	1-White 2-Shield 3-Black 4-Red	1-White 2-Shield 3-Green 4-Brown	1-Yellow 2-Shield 3-Black 4-Red	1-White 2-Shield & Red 3-Blue 4-Blue Yellow-NC	1-White 2-Sh & Black 3-Blue 4-Red	1-Red 2-Sh & Black 3-Blue 4-White
TEABERRY Stalker 9FM Stalker 9FTX	1-Shield 2-Audio 3-Transmit 4-Receive Electronic	1-Sh & Blue 2-White 3-Red 4-Black Yellow-NC	1-Shield 2-White 3-Red 4-Black Electronic	1-Shield 2-White 3-Brown 4-Green	1-Shield 2-Yellow 3-Red 4-Black	1-Shield & Red 2-White 3-Blue 4-Black Yellow-NC	1-Sh & Black 2-White 3-Red 4-Blue	1-Sh & Black 2-Red 3-White 4-Blue
TEABERRY STALKER III	1-Audio 4-Shield 2-NC 3-Transmit 5-Receive	1-White 4-Sh & Blue 2-NC 3-Red 5-Black Yellow-NC	1-White 4-Shield 2-NC 3-Red 5-Black Electronic	1-White 4-Shield 2-NC 3-Brown 5-Green	1-Yellow 4-Shield 2-NC 3-Red 5-Black	1-White 4-Shield & Red 2-NC 3-Blue 5-Black Yellow-NC	1-White 4-Sh & Black 2-NC 3-Red 5-Blue	1-Red 4-Sh & Black 2-NC 3-White 5-Blue
TEABERRY STALKER IV STALKER V STALKER VIII	1-Audio 2-Shield 3-Receive 4-Transmit	1-White 2-Shield & Blue 3-Black 4-Red Yellow-NC	1-White 2-Shield 3-Black 4-Red	1-White 2-Shield 3-Green 4-Brown 4-Red	1-Yellow 2-Shield 3-Black 4-Red	1-White 2-Shield & Red 3-Blue 4-Red Yellow-NC	1-White 2-Sh & Black 3-Blue 4-Red	1-Red 2-Sh & Black 3-Blue 4-White

Mike Type	Standard	ASTATIC	SADELTA	GALAXY	TURNER	GALAXY	DAIWA	
	575M-6, 636L D104M, MB1 1104C & CM T-101, T-1UP Diamond Eagle Golden Eagle Night Eagle, K Silver Eagle, K Road Devi	575M D104C T-101 Stand VALOR PDC60 / Echo	575M D104C T-101 Stand VALOR MB-4 / B. Beep	575M EchoMaster - EchoMaster Pro ME-3 MB-4 / B. Beep	Bravo 500 Expander 300 Road King 56 RK 76	DC-3213 (4 Wts.)	CB-66E1R CB-66E1R COBRA CA-70 CA-71 CA-72 CA-79 CA-80	
	Mike							
	Wiring							
	Model	HOOKUP						
		<i>Color Code</i> White-Audio Shield-Ground Red-Transmit Black-Receive Blue-Common Yellow-Audio Sw	<i>Color Code</i> White-Audio Shield-Ground Red-Transmit Black-Receive	<i>Color Code</i> White-Audio Shield-Ground Brown-Transmit Green-Receive	<i>Color Code</i> Yellow-Audio Shield-Ground Red-Transmit Black-Receive	<i>Color Code</i> White-Audio Shield-Ground Blue-Transmit Black-Receive Red-Common Yellow-Audio Sw	<i>Color Code</i> White-Audio Shield-Ground Red-Transmit Blue-Receive Black-Common	<i>Color Code</i> Red-Audio Shield-Ground White-Transmit Blue-Receive Black-Common
TEABERRY	1-Audio 2-Shield 3-Receive 4-Sw Wire 5-Transmit	1-White 2-Shield 3-Black 4-Blue 5-Red Yellow-NC	1-White 2-NC 3-Black 4-Shield 5-Red	1-White 2-NC 3-Green 4-Shield 5-Brown	1-Yellow 2-NC 3-Black 4-Shield 5-Red	1-White 2-Shield 3-Black 4-Blue 5-Red Yellow-NC	1-White 2-Shield 3-Blue 4-Black 5-White	1-Red 2-Shield 3-Blue 4-Black 5-White
TEABERRY Golden 5x5 TB-71 "T" BEAR Titan "T" T DISPATCH T COMMAND	1-Audio 2-Shield 3-Receive 4-Transmit	1-White 2-Shield & Blue 3-Black 4-Red Yellow-NC	1-White 2-Shield 3-Black 4-Red	1-White 2-Shield 3-Green 4-Brown	1-Yellow 2-Shield 3-Black 4-Red	1-White 2-Shield & Red 3-Black 4-Blue Yellow-NC	1-White 2-Sh & Black 3-Blue 4-Red	1-Red 2-Sh & Black 3-Blue 4-White
TEABERRY RANGER T	1-Shield 2-Receive 3-Transmit 4-Audio	1-Shield & Blue 2-Black 3-Red 4-White Yellow-NC	1-Shield 2-Black 3-Red 4-White Electronic	1-Shield 2-Green 3-Brown 4-White	1-Shield 2-Black 3-Red 4-White	1-Shield & Red 2-Black 3-Blue 4-White Yellow-NC	1-Sh & Black 2-Blue 3-Red 4-White	1-Sh & Black 2-Blue 3-White 4-Red
TEK HR-3950	1-Shield 2-Audio 3-Transmit 4-Receive Electronic	1-Sh & Blue 2-White 3-Red 4-Black Yellow-NC	1-Shield 2-White 3-Red 4-Black Electronic	1-Shield 2-White 3-Brown 4-Green	1-Shield 2-Yellow 3-Red 4-Black	1-Shield & Red 2-White 3-Red 4-Black Yellow-NC	1-Sh & Black 2-White 3-Red 4-Blue Yellow-NC	1-Sh & Black 2-Red 3-White 4-Blue
TRAM D201 D201A TITAN TITAN II TITAN IIA TITAN III TITAN IV	1-Audio 2-Shield 3-Receive 4-Transmit	1-White 2-Shield & Blue 3-Black 4-Red Yellow-NC	1-White 2-Shield 3-Black 4-Red	1-White 2-Shield 3-Green 4-Brown	1-Yellow 2-Shield 3-Black 4-Red	1-White 2-Shield & Red 3-Black 4-Blue Yellow-NC	1-White 2-Sh & Black 3-Blue 4-Red	1-Red 2-Sh & Black 3-Blue 4-White
TRAM D12 D42 D62 Diamond 40 Diamond 60 XL XL-5 XL-23	1-Shield 2-Audio 3-Transmit 4-Receive Electronic	1-Sh & Blue 2-White 3-Red 4-Black Yellow-NC	1-Shield 2-White 3-Red 4-Black Electronic	1-Shield 2-White 3-Brown 4-Green	1-Shield 2-Yellow 3-Red 4-Black	1-Shield & Red 2-White 3-Blue 4-Black Yellow-NC	1-Sh & Black 2-White 3-Red 4-Blue	1-Sh & Black 2-Red 3-White 4-Blue
TRI MAX 220	1-Audio 2-Shield 3-Receive 4-Transmit	1-White 2-Shield & Blue 3-Black 4-Red Yellow-NC	1-White 2-Shield 3-Black 4-Red	1-White 2-Shield 3-Green 4-Brown	1-Yellow 2-Shield 3-Black 4-Red	1-White 2-Shield & Red 3-Black 4-Blue Yellow-NC	1-White 2-Sh & Black 3-Blue 4-Red	1-Red 2-Sh & Black 3-Blue 4-White
TRISTAR 120 240 340 727	1-Audio 2-Shield 3-Receive 4-Transmit	1-White 2-Shield & Blue 3-Black 4-Red Yellow-NC	1-White 2-Shield 3-Black 4-Red	1-White 2-Shield 3-Green 4-Brown	1-Yellow 2-Shield 3-Black 4-Red	1-White 2-Shield & Red 3-Black 4-Blue Yellow-NC	1-White 2-Sh & Black 3-Blue 4-Red	1-Red 2-Sh & Black 3-Blue 4-White

Mike Type	Standard	ASTATIC	ASTATIC	SADELTA	GALAXY	TURNER	GALAXY	DAIWA
Model	MIKE	ASTATIC	ASTATIC	SADELTA	GALAXY	TURNER	GALAXY	DAIWA
Model	HOOKUP	Color Code	Color Code	Color Code	Color Code	Color Code	Color Code	Color Code
TR5-Challenger	1-Audio 2-Shield 3-Receive 4-Transmit	1-White 2-Shield & Blue 3-Black 4-Red Yellow-NC	1-White 2-Shield 3-Black 4-Red	1-White 2-Shield 3-Black 4-Brown	1-White 2-Shield 3-Green 4-Red	1-White 2-Shield & Red 3-Black 4-Blue Yellow-NC	1-White 2-Sh & Black 3-Blue 4-Red	1-Red 2-Sh & Black 3-Blue 4-White
UNIDEN/ PRESIDENT AR7 AN7	1-Audio 4-NC 2-Transmit 3-Receive 3-Shield	1-White 4-NC 2-Red 5-Black 3-Shield & Blue Yellow-NC	1-White 4-NC 2-Red 5-Black 3-Shield Electronic	1-White 4-NC 2-Brown 3-Shield	1-Yellow 4-NC 2-Red 3-Black 3-Shield	1-White 4-NC 2-Blue 3-Black 3-Shield & Red Yellow-NC	1-White 4-NC 2-Red 3-Blue 3-Sh & Black	1-Red 4-NC 2-White 3-Blue 3-Sh & Black
UNIDEN/ PRESIDENT PC-33K PC-35X PRO-510e PRO-520e P200 P210	1-Audio 4-Shield 2-Transmit 5-Receive 3-NC	1-White 4-Sh & Blue 2-Red 3-Black 5-NC Yellow-NC	1-White 4-Shield 2-Red 3-Black 3-NC Electronic	1-White 4-Shield 2-Brown 3-NC	1-Yellow 4-Shield 2-Red 3-Green 3-NC	1-White 4-Shield & Red 2-Blue 5-Black 3-NC Yellow-NC	1-White 4-Sh & Black 2-Red 5-Blue 3-NC	1-Red 4-Sh & Black 2-White 5-Blue 3-NC
UNIDEN ADAMS ANDREW J CONVOY II DOWGHT D GRANT (858) GRANT-DX HONEST ABE JACKSON JOHN Q MADISON (858) OLD HICKORY TEDDY R THOMAS J VEEP Washington (858) ZACHARY T ARA, AX4 AR14, AX34 AX3 AR44, AX44 AR144, AX144 AR711, AX711 P220 P300 PC33 PC55 PC66A, PC66XL PC76XL PC76XLW PC77 PC122, PC122XL PC244 PRO-500D PRO-510 XL PRO-520 XL PRO-530E PRO-535e PRO-538e PRO-540e PRO-640e PRO-710e PRO-810e PTC-104	1-Shield 3-Audio 3-Transmit 4-Receive Electronic	1-Shield & Blue 2-White 3-Red 4-Black Yellow-NC	1-Shield 2-White 3-Red 4-Black Electronic	1-Shield 2-White 3-Brown 4-Green	1-Shield 2-Yellow 3-Red 4-Black	1-Shield & Red 2-White 3-Blue 4-Black Yellow-NC	1-Sh & Black 2-White 3-Red 4-Blue	1-Sh & Black 2-Red 3-White 4-Blue

Mike Type	Standard	ASTATIC	ASTATIC	SADELTA	GALAXY	TURNER	GALAXY	DAIWA
	<i>Mike</i>	575M-6, 651L D104M, M6B 1104C & CM T-DGG, T-1P9	575M D104M T-DGG Stand VALOR	Bravo Plus Echomaster 4 Echomaster Pro ME-3 MB-4-R. Bosp	DC-5215 (4 wire)	Expander 550 Road King 56 RK76	CB-6601R CB-6601R	COBRA CA-70 CA-71 CA-72 CA-79 CA-80
	<i>Wiring</i>	Diamond Eagle Golden Eagle Night Eagle, K Silver Eagle, K Road Devil	FDCC67/Elec2					
Model	HOOKUP	<i>Color Code</i> White-Audio Shield-Ground Red-Transmit Black-Receive Blue-Common Yellow-Audio Sw	<i>Color Code</i> White-Audio Shield-Ground Red-Transmit Black-Receive	<i>Color Code</i> White-Audio Shield-Ground Brown-Transmit Green-Receive	<i>Color Code</i> Yellow-Audio Shield-Ground Red-Transmit Black-Receive	<i>Color Code</i> White-Audio Shield-Ground Blue-Transmit Black-Receive Red-Common Yellow-Audio Sw	<i>Color Code</i> White-Audio Shield-Ground Red-Transmit Blue-Receive Black-Common	<i>Color Code</i> Red-Audio Shield-Ground White-Transmit Blue-Receive Black-Common
UNIDEN GRANT GRANT XL MADISON (8719) McKinley P400 Washington (8719)	1-Audio 2-Shield 3-Receive 4-Sw Wire 5-Transmit 4-Receive	1-White 2-Shield 3-Black 4-Blue 5-Red Yellow-NC	1-White 2-NC 3-Black 4-Shield 5-Red	1-White 2-NC 3-Gen 4-Shield 5-Brown	1-Yellow 2-NC 3-Black 4-Shield 5-Red	1-White 2-Shield 3-Blue 4-Red 5-Blue Yellow-NC	1-White 2-Shield 3-Blue 4-Black 5-Red Black-Common	1-Red 2-Shield 3-Blue 4-Black 5-White
UNIDEN HR-2510 HR-2600 LINCOLN	1-Audio 2-Shield 3-Transmit 4-Ch 5-Ch	1-White 2-Shield & Blue 3-Red 4-NC 5-NC Black-NC Yellow-NC	1-White 2-Shield 3-Red 4-NC 5-NC Black-NC Electronic	1-White 2-Shield 3-Brown 4-NC 5-NC Green-NC	1-Yellow 2-Shield 3-Red 4-NC 5-NC Black-NC	1-White 2-Shield & Red 3-Blue 4-NC 5-NC Blue-NC Yellow-NC	1-White 2-Red 3-Red 4-NC 5-NC Blue-NC	1-Red 2-White 3-Blue 4-NC 5-NC Blue-NC
UTAC Studio 4000	1-Audio 2-Transmit 3-Shield Electronic or Relay	1-White 2-Shield & Blue 3-Shield & Blue Yellow-NC Black-NC	1-White 2-Shield 3-Sh & Black Electronic or Relay	1-White 2-Brown 3-Sh & Green	1-Yellow 2-Red 3-Sh & Black	1-White 2-Blue 3-Shield & Red Yellow-NC Black-NC	1-White 2-Red 3-Sh & Black Blue-NC	1-Red 2-White 3-Sh & Black Blue-NC
YOSAN JC-2204	1-Audio 2-Shield 3-Receive 4-Transmit	1-White 2-Shield & Blue 3-Black 4-Red Yellow-NC	1-White 2-Shield 3-Black 4-Red	1-White 2-Shield 3-Green 4-Brown	1-Yellow 2-Shield 3-Red 4-Red	1-White 2-Shield & Red 3-Black 4-Blue Yellow-NC	1-White 2-Red 3-Blue 4-Red	1-Red 2-White 3-Blue 4-White
WELL W-605 W-705	1-Audio 2-Shield 3-Transmit 4-Receive	1-White 2-Shield & Blue 3-Red 4-Black Yellow-NC	1-White 2-Shield 3-Red 4-Black	1-White 2-Shield 3-Brown 4-Green	1-Yellow 2-Shield 3-Red 4-Black	1-White 2-Shield & Red 3-Blue 4-Black Yellow-NC	1-White 2-Red 3-Blue 4-Blue	1-Red 2-White 3-Blue 4-Blue
ZODIAC M-5023	1-Audio 2-Shield 3-Transmit 4-NC 5-Receive Electronic	1-White 2-Shield & Blue 3-Red 4-NC 5-Black Yellow-NC	1-White 2-Shield 3-Red 4-NC 5-Black Electronic	1-White 2-Shield 3-Brown 4-NC 5-Green	1-Yellow 2-Shield 3-Red 4-NC 5-Black	1-White 2-Shield & Red 3-Blue 4-NC 5-Black Yellow-NC	1-White 2-Red 3-Red 4-NC 5-Blue	1-Red 2-White 3-White 4-NC 5-Blue
ZODIAC M-5026	1-Audio 2-Ground 3-Transmit 4-Shield 5-NC RELAY	1-White 2-Blue 3-Red 4-Shield 5-NC Black-NC Yellow-NC	1-White 2-Black 3-Red 4-Shield 5-NC	1-White 2-Green 3-Brown 4-Shield 5-NC	1-Yellow 2-Black 3-Red 4-Shield 5-NC	1-White 2-Red 3-Blue 4-Shield 5-NC Black-NC Yellow-NC	1-White 2-Black 3-Red 4-Shield 5-NC Blue-NC	1-Red 2-Black 3-White 4-Shield 5-NC Blue-NC



GALAXY SATURN
SERVICE/OWNERS MANUAL
 COMPLETE with
 Schematics
 Operating Instructions
 Complete Voltage Information
 Transistor & IC Pin-Outs
 Repair & Conversion Tips
 Channel Charts for 5 & 6 Band Versions
 Available from your Local Dealer or Distributor

Although this manual is written to cover the Galaxy Saturn, it can also be used on many other Export Radios with the same circuit board. Such as the SUPER GALAXY, MIRAGE 88, GALAXY II, GALAXY 77HML, 77V, GALAXY 88HML, 88V, and many others.

Master Index (For Volume 1 Thru Volume 7)

Using the Master Index

	← Radio Make & Model or Models	
COBRA RADIOS	← Subject	
19 PLUS		← Volume / Page
Repair Tip 2 / 31	
Power Modification 2 / 07	
Variable Adjustments 3 / 34	

Note : This INDEX covers the latest revised edition of CB TUNE-UP MANUAL MASTER EDITION Volume 1. The new revised edition has the same information as the old Volume 1 but with a new improved format for ease of use. Although the information is the same, unfortunately it will not be on the same page as the old Volume 1. Please keep this in mind when using this index for subject matter contained in the old version of Volume 1. *Thank You!*

SUBJECT INDEX

CHANNEL CONVERSIONS	
858 PLL Chip	2 / 15-23
8719 PLL Chip	2 / 24-29
PLL-G2A Chip	2 / 10-14
Component Identification	5 / 48
Correction for Volume II (Page 25)	2 / 25
Corrections	5 / 06
Correction for 858 Clarifier Mod	3 / 21
ECHO BOARD Installation	
EPTOSSBOR (Corners)	7 / 37
Improving Radio Performance	3 / 06
MICROPHONE WIRING CHARTS	
Volume II	2 / 34-43
Volume III	3 / 39-45
Volume 4	4 / 52-58
Volume 5	5 / 49-51
Volume 6	6 / 40-50
REPAIR TIP	
ALL RADIOS	
Over-Modulation	1 / 61
SCANNER REPAIR TIPS	
BC-140XL, BC-142XL, BC-145XL	2 / 46
No Audio, Unit still Scans & Prog	2 / 47
No scan, no audio or squelch	2 / 48
BC-147XL	2 / 46
No Audio, Unit still Scans & Prog	2 / 46
BC-210XL	2 / 44
No Digt Display or very Dim	2 / 44
BC-210XW	2 / 45
No Digt Display or very Dim	2 / 45
BC-800XL	3 / 47
No Digt Display or very Dim	3 / 47
Voltage Pin-Out Information	3 / 48-50
BC-855XL	2 / 47
Cellular Restoration Mod	
BEARCAT 2020	2 / 45
No Digt Display or very Dim	2 / 45
STANDARD 40 CH. Freq. Chart	
SUPER-TALK INSTALLATION	
General Installation Instructions	3 / 27
ANDREW 1F	2 / 06
AR44, AX44	2 / 06
F20	2 / 08
AR-711, AX-711	2 / 06
COBRA 210TDL, 250TDL, 25LTD	2 / 06
COBRA 29LTD or LTD Classic	2 / 04-05
COBRA 142GTL Installation	3 / 26
(Same as Washington)	
COBRA 3000GTL	4 / 10
CONNEX 3300	4 / 18
HONEST ABE Installation	3 / 28
F20	2 / 08
REALISTIC TRC-432	5 / 27
REALISTIC TRC-490	5 / 28
SUPERSTAR 3900	4 / 22
T BEAR Installation	3 / 28
UMDEN PC6B, PC6SA	2 / 08
UMDEN WASHINGTON Install.	3 / 28
TALK BACK	
Conversion Mod. for Export Radios	3 / 30

CB RADIO INDEX

ACTONLINE RADIOS	
HC-10	
Tune-Up	1 / 04

ALAN RADIOS	
ALAN 555	
ALAN550	
Tune-Up	6 / 04
ALARON RADIOS	
B-1025	B-4085
B-1100	B-4000
B-1150	B-5000A
B-4075	B-6200
Tune-Up	1 / 04
AMERICAN ELECTRONICS RADIOS	
76-501	76-601
76-851	
Tune-Up	1 / 04
ARGO RADIOS	
ARGO 200	
Tune-Up	1 / 04
ARGUS RADIOS	
5000	
Tune-Up	1 / 05
ALICHOVIX RADIOS	
100	
Tune-Up	1 / 05
CB-25	
Tune-Up	2 / 02
MCB-500	MCB-3000
MCB-750	MCB-5000
MCB-1000	MDU-6000
MCB-2000	WINDSOR
Tune-Up	1 / 05
AUTOMATIC RADIOS	
CBH-2285	
Tune-Up	1 / 05
BELTEX RADIOS	
ENDURO S & ENDURO 23	
Tune-Up	1 / 05
BETA RADIOS	
BETA 23 DELUXE	
Tune-Up	1 / 05
BOMAN RADIOS	
CB-515	CB-750
CB-555	CB-770
CB-720B	CB-775
CB-725	
Tune-Up	1 / 07
CB-910	
Channel Conversion	2 / 11-14
Tune-Up	1 / 05
CB-820	
Channel Conversion	2 / 11-14
Tune-Up	1 / 05
CB-930	
Channel Conversion	2 / 11-14
Tune-Up	1 / 05
CB-950	
Tune-Up	1 / 05
CBH-900	CBR-9000
CBH-990	CBR-9940
CBH-6100	CBR-9950
CBR-9900	
Tune-Up	1 / 06

BRISTOL RADIOS	
CB-2711	
Tune-Up	1 / 08
BROWNING RADIOS	
BROWN	
BROWNIE 23	
Tune-Up	1 / 08
BROWNIE 40	
Channel Conversion	2 / 15-17
Tune-Up	1 / 08
LTD	
MARK 4A	
SABRE	
SST(Early Production)	
SST(Late Production)	
SST 2	
Tune-Up	1 / 08
CALTRON RADIOS	
CB-7500	
Tune-Up	1 / 08
CHANNEL MASTER RADIOS	
CB-8830	CB-8834
CB-8832	CB-8835
Tune-Up	1 / 08
CLARICOR RADIOS	
71200	
ACTWATOR (30000)	
Tune-Up	1 / 08
INTRUDER (30200)	
PIRATE (30400)	
Tune-Up	1 / 07
PRIVATEER(30600)	
RAIDER	
Tune-Up	1 / 08
CLARION RADIOS	
DMA-066	PE-672E
JC-201E (CB UNIT)	RCJ-003
JC-202E	TC-203C
JC-203E	
Tune-Up	1 / 07
COBRA RADIOS	
7 PLUS	
Tune-Up	1 / 07
10 PLUS	
Tune-Up	1 / 07
18 LTD	
Tune-Up	1 / 07
18 PLUS	
Tune-Up	1 / 07
18 RV	
Power Modification	1 / 50
Tune-Up	1 / 07
18 ULTRA	
Tune-Up	6 / 04
Variable Alignments	6 / 31
19	
Tune-Up	1 / 07
190X LTD (Limited Edition)	
Tune-Up	7 / 04
Variable Adjustments	7 / 39
19 GTL	
Power Modification	1 / 50
Tune-Up	1 / 07
Variable Adjustments	4 / 45

19 LTD	
Tune-Up	1 / 07
19 LTD Classic	
Tune-Up	1 / 07
19M	
Tune-Up	1 / 07
19 PLUS (Metal Case Model)	
Tune-Up	1 / 07
19 PLUS (Plastic Case Model)	
Power Modification	2 / 07
Repair Tip	2 / 31
Tune-Up	1 / 07
Variable Adjustments	3 / 34
19XS	
Tune-Up	1 / 07
20 (BSK)	
Tune-Up	1 / 07
20 LTD	
Tune-Up	1 / 07
20 PLUS	
Tune-Up	1 / 07
20 PLUS (Plastic Case Model)	
Tune-Up	1 / 07
21	
Tune-Up	1 / 07
21A (Old Version)	
Tune-Up	1 / 07
21GTL	
Power Modification	1 / 49
Tune-Up	1 / 07
21LTD	
Super-Talk Installation	2 / 06
21LTD	
Power Modification	1 / 49
Tune-Up	1 / 07
21 LTD Classic	
Tune-Up	1 / 07
21 LTD Classic (New Model made in China)	
Tune-Up	6 / 04
Variable Adjustments	6 / 31
21 PLUS	
Tune-Up	1 / 07
21X	
Tune-Up	1 / 07
21XLR	
Power Modification	1 / 50
Tune-Up	1 / 08
23 PLUS	
Power Modification	1 / 50
Tune-Up	1 / 08
25GTL	
Power Modification	1 / 49
Tune-Up	1 / 08
Super-Talk Installation	2 / 06
25LTD, Classic, Classic Gold	
Power Modification	2 / 07
Super-Talk Installation	2 / 06
Tune-Up	1 / 08
25LTD WK Classic	
Power Modification	2 / 06
Tune-Up	6 / 04
Variable Adjustments	6 / 31
25 PLUS	
Tune-Up	1 / 08
Variable Adjustments	4 / 45
26	
Tune-Up	1 / 08

Master Index (For Volume 1 Thru Volume 7)

26A		Clarifier Conversion	2/20	Repair Tip	2/31	Tune-Up	1/10
	Tune-Up	Power Mod (Cobra 139XLR)	1/51	Repair Tip (No Modulation)	5/43		
26A (Old Model)	1/08	Repair Tip (Regulator Failure)	1/60	Super Slide Modification	4/06	CONNEX RADIOS	
26GTL		Tune-Up	1/09	Super-Talk Installation	4/10	3300	
	Power Modification	Welding Procedure	2/20	Variable Adjustments	1/62	Tune-Up	1/10
	Tune-Up	139		HH-70		Super-Talk Installation	4/18
25A,TD Classic, Classic Gold		Tune-Up	1/09	Tune-Up	6/04	10 KHz Jump Modification	4/19
	Power Modification	129XLR		Variable Adjustments	6/31	Variable Adjustments	5/45
	Super-Talk Installation Diagram	Channel Conversion#1	2/18,19			CONVOY RADIOS	
	Tune-Up	Channel Conversion #2 (Rotary)	2/22	COLT RADIOS		CON-400	
	Variable Adjustments	Channel Conversion #3	2/23	EXCALBUR (EPT360010Z Board)		Tune-Up	1/11
20 VIX Classic	3/34	Power Modification	2/20	Tune-Up	1/10	Tune-Up (Correction for Old Vol.)	3/05
	Power Modification	Power Modification	1/51	Variable Adjustments	1/64	CON-430	
	Tune-Up	Repair Tip (Regulator Failure)	1/60	EXCALBUR (PTMB121DX4 Board)		CON-450	
	Variable Adjustments	Tune-Up	1/09	Tune-Up	1/10	Tune-Up	1/11
23 PLUS		Welding Procedure	2/20	Variable Adjustments	1/64		
	Tune-Up	140GTL		SX33		COURIER RADIOS	
29XL		Channel Conversion	2/27	Channel Conversion	2/11-14	BLAZER 400	
	Channel Conversion	Clarifier Conversion	2/27	Tune-Up	1/09	Tune-Up	1/11
	Power Modification	Power Modification	1/51	190		CADET	
	Tune-Up	Repair Tip (Regulator Failure)	1/60	210		CARAVELLE II	
31 PLUS (Correction Old Vol.)	3/05	Tune-Up	1/09	222		CARAVELLE 400	
	Variable Adjustments	Variable Adjustments	1/62	290		CENTURIAN 23	
32XLR		142GTL		Tune-Up	1/09	CENTURIAN 400	
	Channel Conversion	Channel Conv. w/10Xl Change	2/27	3200X			
	Tune-Up	Tune-Up. w/o Xtl Change	3/12	Tune-Up	1/09	CENTURIAN PL40	1/11
33 PLUS	1/08	Clarifier Conversion #1	2/27	Variable Adjustments	1/54	Tune-Up	1/11
	Tune-Up	Clarifier Conversion w/10 Turn Pot	3/14	320FM		Variable Adjustments	5/45
	Variable Adjustments	Power Modification	1/51	Tune-Up	1/09	CLASSIC II	1/11
36 LTD (S.D.S.)	3/34	Repair Tip (Regulator Failure)	1/60	Variable Adjustments	1/64	CLASSIC III	
40 PLUS		Tune-Up	1/09	350		CLASSIC IV	
	Tune-Up	Variable Adjustments	1/62	Tune-Up	1/09	CLASSIC PL40	
40X		146GTL		Tune-Up (Correction for Old Vol.)	3/05	CONQUEROR II	
	Tune-Up	Clarifier Modification	4/30	355		CONQUEROR 400	
	Variable Adjustments	148GTL		Tune-Up	1/09	CRUISER	1/11
41 PLUS	1/08	Channel Conversion(Switch)	2/24	357 (New Chassis Model)		GALAXY	
45 XLR		Clarifier Conversion	2/25	Tune-Up	1/09	GALAXY IV	
47 XLR		Clarifier Conversion(Update)	3/25	Variable Adjustments	4/45	GALAXY V	
50 XLR		Power Modification	1/51	357 (Old Chassis Model)		GALAXY VI	
55 XLR		Repair Tip (Regulator Failure)	1/60	Tune-Up	1/10	Tune-Up	1/11
52 XLR		Tune-Up	1/09	359		GLADIATOR	
63 GTL		Tune-Up	1/09	Tune-Up	3/02	NIGHTRIDER 40DR	
	Tune-Up	148GTL (New Model made in Malaysia)	6/18	Variable Adjustments	2/33	REBEL 23	
66 GTL	1/08	Clarifier Slide Modification	6/18	390		REBEL 40A	
	Tune-Up	Rotary Switch Ch. Conversion	6/22	Channel Conversion	2/11-14	REBEL PLL	
77X		Rotary Switch Ch. Chart	6/23	Tune-Up	1/10	REDBALL	
	Power Modification	Super Slide Clarifier Modification	6/19	Tune-Up	1/10	RENEGADE 40	
	Tune-Up	Switch Channel Conversion	6/20	Variable Adjustments	1/62	ROGUE 40	
78X		Switch Channel Chart	6/20	480		SPARTAN 55B	
	Power Modification	Tune-Up	6/04	Tune-Up	1/10	TRAVELLER II	
	Tune-Up	Variable Adjustments	6/31	Clarifier Modification	5/25	Tune-Up	1/11
85		148F-GTL (Has Freq. Counter)	7/29	Variable Adjustments	5/45		
	Power Modification	Clarifier Slide Modification	7/29	485		C.P.I. RADIOS	
	Tune-Up	Rotary Switch Ch. Conversion	7/33	486X		CP400	
88		Rotary Switch Ch. Chart	7/34	870 (Export)		Tune-Up	1/11
	Variable Adjustments	Super Slide Clarifier Modification	7/30	Tune-Up	1/10		
89		Switch Channel Conversion	7/31	1000		CRAIG RADIOS	
80XLR		Switch Channel Chart	7/32	Clarifier Modification	5/25	4101	4104
	Channel Conversion	Tune-Up	7/04	Variable Adjustments	1/10	4102	4201
	Tune-Up	Variable Adjustments	7/39	510		4103	
	Variable Adjustments	148GTL-B		800		Tune-Up	1/12
87GTL		Tune-Up	1/09	870		L-101	
	Power Modification	148GTL (Fake Version)		Tune-Up	1/10	Tune-Up	1/12
	Tune-Up	Tune-Up	1/09	1200		Variable Adjustments	6/31
CAM 89	1/08	Variable Adjustments	1/65	1200DX		L-102	
	Tune-Up	148GTL-DX (Early Production)		Tune-Up	1/10	Variable Adjustments	6/31
89GTL		Tune-Up	1/09	1600DX		L-103	
	Power Modification	Variable Adjustments	1/62	Tune-Up	1/10	Variable Adjustments	6/31
	Tune-Up	148GTL-DX (Late Production Model)		2000DX		L-104	
89XLR		Power Modification	1/51	Tune-Up	1/10	Power Modification	1/51
	Channel Conversion	Variable Adjustments	1/64	Tune-Up	1/10	Tune-Up	1/12
	Power Modification	148GTL-DX (Copy Version)	1/09	Variable Adjustments	1/65	Variable Adjustments	6/31
	Tune-Up	GTL	1/09	2400		L-131	
90LTD	1/50	Tune-Up	1/09	Tune-Up	1/10	Tune-Up	1/12
	Tune-Up	1000GTL		Variable Adjustments	1/65	Variable Adjustments	6/32
93 LTD-WX	1/09	Power Modification	1/50	COMMANDO RADIOS		L-132	
	Tune-Up	Tune-Up	1/09	2310	2325	L-150	
	Variable Adjustments	2000GTL		2320	2340	Tune-Up	1/12
132 (Old Version)	7/39	Channel Conv. #1(Toggle Sw.)	3/24	Tune-Up	1/10	L-231	
132A		Channel Conv. #2(Rotary Sw.)	3/16	COMMTRON RADIOS		Tune-Up	1/12
132 XLR		Channel Conv. 11,125 KHz Rot.	4/08	COX		Variable Adjustments	4/45
134		Clarifier Conversion #1	2/25	Microphone Wiring	2/36	Variable Adjustments	6/32
135 (Old Version)		Clarifier Conversion #1	3/25	Mike Wiring	2/35	L-232	
135 XLR		Clarifier Super Slide w/10 Pot.	4/06	Power Modification	1/51	L-600	
136A		Repair Tip (Regulator Failure)	1/60	Repair Tip(Freq Counter)	1/59	Tune-Up	1/12
	Tune-Up	140GTL		Repair Tip (Regulator Failure)	1/60		
130XLR	1/09						
	Channel Conversion #1						
	Channel Conversion #2 (Rotary)						
	Channel Conversion #3						

Master Index *(For Volume 1 Thru Volume 7)*

Variable Adjustments	6/34	76-858	Channel Conversion	2/11	77-853	Channel Conversion	2/11	Channel Conversion	2/11
LAKE RADIOS		Tune-Up	1/25	77-856	Tune-Up	1/25	Tune-Up	1/27	Tune-Up
410		76-860	Tune-Up	77-857	Variable Adjustments	1/25	77-858	Channel Conversion	2/11-14
450		Tune-Up	1/25	77-858	Channel Conversion	2/11-14	77-859	Tune-Up	1/25
Tune-Up	1/23	76-863	Variable Adjustments	3/35	77-859	Tune-Up	77-861	Tune-Up	1/25
600		76-886	Channel Conversion	2/11	77-861	Tune-Up	77-862	Channel Conversion	2/11
Tune-Up	1/23	77-003(3001)	Tune-Up	1/25	77-862	Channel Conversion	77-863	Channel Conversion	2/11-14
Variable Adjustments	4/47	Tune-Up	1/26	77-863	Channel Conversion	2/11-14	77-864	Tune-Up	1/26
650		Variable Adjustments	4/47	77-864	Tune-Up	1/26	77-865	Variable Adjustments	3/35
750		77-099	Power Modification	1/52	77-865	Variable Adjustments	77-866	Variable Adjustments	3/35
5000 (SN-16)		Tune-Up	1/25	77-866	Channel Conversion	2/11-14	77-867	Channel Conversion	2/11-14
5100 (SN-14)		Variable Adjustments	5/04	77-867	Channel Conversion	2/11-14	77-868	Channel Conversion	2/11-14
Tune-Up	1/23	77-092	Variable Adjustments	5/04	77-868	Tune-Up	77-869	Channel Conversion	2/11-14
LINCOLN RADIOS		Tune-Up	1/25	77-869	Channel Conversion	2/11-14	77-870	Channel Conversion	2/11-14
1500		Variable Adjustments	5/04	77-870	Channel Conversion	2/11-14	77-871	Channel Conversion	2/11-14
Tune-Up	1/23	77-094	Tune-Up	1/25	77-871	Channel Conversion	77-872	Channel Conversion	2/11-14
MARKO RADIOS		Tune-Up	1/25	77-872	Channel Conversion	2/11-14	77-873	Channel Conversion	2/11-14
CB-444		Variable Adjustments	3/35	77-873	Channel Conversion	2/11-14	77-874	Channel Conversion	2/11-14
Tune-Up	1/23	77-099	Power Modification	1/52	77-874	Channel Conversion	77-875	Channel Conversion	2/11-14
MAXON RADIOS		Tune-Up	1/25	77-875	Channel Conversion	2/11-14	77-876	Channel Conversion	2/11-14
LP-27		77-101B	Tune-Up	1/25	77-876	Channel Conversion	77-877	Channel Conversion	2/11-14
Tune-Up	2/03	77-101C	Tune-Up	1/25	77-877	Channel Conversion	77-878	Channel Conversion	2/11-14
MCB-25		Variable Adjustments	4/47	77-878	Channel Conversion	2/11-14	77-879	Channel Conversion	2/11-14
MCB-30		Variable Adjustments	4/47	77-879	Channel Conversion	2/11-14	77-880	Channel Conversion	2/11-14
Tune-Up	6/05	77-102(102M)	Variable Adjustments	4/47	77-880	Channel Conversion	77-881	Channel Conversion	2/11-14
Variable Adjustments	6/34	Tune-Up	1/25	77-881	Channel Conversion	2/11-14	77-882	Channel Conversion	2/11-14
MCB-60		Variable Adjustments	3/35	77-882	Channel Conversion	2/11-14	77-883	Channel Conversion	2/11-14
Tune-Up	7/05	77-104XL	Variable Adjustments	4/47	77-883	Channel Conversion	77-884	Channel Conversion	2/11-14
Variable Adjustments	7/40	Tune-Up	7/05	77-884	Channel Conversion	2/11-14	77-885	Channel Conversion	2/11-14
MEDALLION RADIOS		Variable Adjustments	7/40	77-885	Channel Conversion	2/11-14	77-886	Channel Conversion	2/11-14
63-030		77-106	Tune-Up	1/25	77-886	Channel Conversion	77-887	Channel Conversion	2/11-14
Channel Conversion	2/11	77-145	Tune-Up	1/25	77-887	Channel Conversion	77-888	Channel Conversion	2/11-14
Tune-Up	1/23	79-892	Variable Adjustments	3/35	77-888	Channel Conversion	77-889	Channel Conversion	2/11-14
63-200	63-540	79-891	Variable Adjustments	3/35	77-889	Channel Conversion	77-890	Channel Conversion	2/11-14
63-240		79-892	Variable Adjustments	3/35	77-890	Channel Conversion	79-900 (Old Model)	Channel Conversion	2/11-14
Tune-Up	1/23	79-893	Variable Adjustments	3/35	79-900 (New Model)	Tune-Up	79-900 (New Model)	Tune-Up	1/26
METRO SOUND RADIOS		77-112	Tune-Up	1/25	79-900 (New Model)	Tune-Up	100M	Tune-Up	1/26
CB-1		77-116	Power Modification	1/53	101M	Tune-Up	102M	Tune-Up	1/26
Tune-Up	1/24	Tune-Up	1/25	77-145	102M	Tune-Up	103M	Tune-Up	1/26
MIDLAND RADIOS		77-149	Variable Adjustments	3/35	104M	Tune-Up	105M (77-150)	Tune-Up	1/26
13-700	13-779	77-151(151M)	Power Modification	1/53	105M (77-150)	Tune-Up	200M (77-200)	Power Modification	2/08
13-729	13-796	77-155	Tune-Up	1/25	200M (77-200)	Power Modification	Power Modification	1/52	
Tune-Up	1/24	Tune-Up	1/25	77-155	Power Modification	1/52	Tune-Up	1/26	
13-830		77-200 (200M)	Variable Adjustments	5/04	1001 (Export Model)	Tune-Up	1001 (Export Model)	Variable Adjustments	6/34
Power Modification	1/52	Tune-Up	1/26	77-202A	1001 (Export Model)	Variable Adjustments	1001 (Export Model)	Variable Adjustments	4/47
Tune-Up	1/24	77-202B	Tune-Up	1/26	Tune-Up	1/26	1001 (Export Model)	Variable Adjustments	4/47
13-845	13-871	77-202A	Variable Adjustments	6/34	3001(77-003)	Tune-Up	3001(77-003)	Tune-Up	1/26
13-852	13-879	Tune-Up	1/25	77-202B	Tune-Up	1/26	3001(77-003)	Variable Adjustments	4/47
13-853	13-879B	77-202B	Tune-Up	1/26	77-202A	Variable Adjustments	77-202A	Variable Adjustments	6/34
13-854	13-881	77-202B	Variable Adjustments	6/34	Tune-Up	1/26	Tune-Up	1/26	
13-857	13-882	77-202B	Variable Adjustments	6/34	5001 (77-005)	Tune-Up	5001 (77-005)	Variable Adjustments	1/26
13-858	13-882B	77-202B	Variable Adjustments	6/34	5001 (77-005)	Variable Adjustments	5001 (77-005)	Variable Adjustments	1/26
13-862	13-882C	77-202B	Variable Adjustments	6/34	6001 (79-012 only)	Tune-Up	6001 (79-012 only)	Tune-Up	1/26
13-862B	13-883	77-202B	Variable Adjustments	6/34	6001 (79-006)	Tune-Up	6001 (79-006)	Tune-Up	1/27
13-863	13-883B	77-202B	Variable Adjustments	6/34	7001	Tune-Up	7001	Tune-Up	1/27
13-863B	13-884	77-202B	Variable Adjustments	6/34	7001 (uPD 2824 chip)	Tune-Up	7001 (uPD 2824 chip)	Tune-Up	1/27
13-866	13-886	77-202B	Variable Adjustments	6/34	7001	Tune-Up	7001	Tune-Up	1/27
13-867	13-887	77-202B	Variable Adjustments	6/34	7001	Tune-Up	7001	Tune-Up	1/27
13-8700		77-250 & 77-250G (Power Max)	Power Modification	1/53	77-821	Tune-Up	77-821	Tune-Up	1/25
Tune-Up	1/24	Power Modification	1/53	77-824	Tune-Up	1/25	77-824	Tune-Up	1/25
13-888B		Tune-Up	1/25	77-824B	Tune-Up	1/25	77-824B	Tune-Up	1/25
Power Modification	1/52	77-285	Tune-Up	6/05	77-824C	Variable Adjustments	77-824C	Variable Adjustments	4/47
Tune-Up	1/24	77-808	Variable Adjustments	4/47	77-824C	Variable Adjustments	77-824C	Variable Adjustments	1/25
13-892	13-895	77-808	Variable Adjustments	4/47	77-824C	Variable Adjustments	77-824C	Variable Adjustments	1/25
13-893	13-896	77-808	Variable Adjustments	4/47	77-824C	Variable Adjustments	77-824C	Variable Adjustments	1/25
13-894		77-821	Tune-Up	1/25	77-824C	Variable Adjustments	77-824C	Variable Adjustments	1/25
Tune-Up	1/24	Tune-Up	1/25	77-824	Channel Conversion	2/11-14	77-849	Channel Conversion	2/11-14
13-898		77-824	Channel Conversion	2/11-14	77-849	Channel Conversion	77-849	Channel Conversion	2/11-14
13-988B		77-824B	Channel Conversion	2/11-14	77-849	Channel Conversion	77-849	Channel Conversion	2/11-14
Tune-Up	1/25	77-824B	Channel Conversion	2/11-14	77-849	Channel Conversion	77-849	Channel Conversion	2/11-14
13-955		77-824B	Channel Conversion	2/11-14	77-849	Channel Conversion	77-849	Channel Conversion	2/11-14
Power Modification	1/52	77-824B	Channel Conversion	2/11-14	77-849	Channel Conversion	77-849	Channel Conversion	2/11-14
Tune-Up	1/25	77-824B	Channel Conversion	2/11-14	77-849	Channel Conversion	77-849	Channel Conversion	2/11-14
13-976		77-824C	Channel Conversion	2/11-14	77-849	Channel Conversion	77-849	Channel Conversion	2/11-14
Tune-Up	1/25	77-824C	Channel Conversion	2/11-14	77-849	Channel Conversion	77-849	Channel Conversion	2/11-14
52-100 (Caravan)	63-445	77-830	Channel Conversion	2/11-14	77-849	Channel Conversion	77-849	Channel Conversion	2/11-14
Tune-Up	1/25	77-830	Channel Conversion	2/11-14	77-849	Channel Conversion	77-849	Channel Conversion	2/11-14
63-445		77-830	Channel Conversion	2/11-14	77-849	Channel Conversion	77-849	Channel Conversion	2/11-14
Variable Adjustments	6/34	77-830	Channel Conversion	2/11-14	77-849	Channel Conversion	77-849	Channel Conversion	2/11-14
75-900		77-830	Channel Conversion	2/11-14	77-849	Channel Conversion	77-849	Channel Conversion	2/11-14
Tune-Up	7/05	77-830	Channel Conversion	2/11-14	77-849	Channel Conversion	77-849	Channel Conversion	2/11-14
75-300 (Am Base)		77-830	Channel Conversion	2/11-14	77-849	Channel Conversion	77-849	Channel Conversion	2/11-14
Power Modification	1/52	77-830	Channel Conversion	2/11-14	77-849	Channel Conversion	77-849	Channel Conversion	2/11-14
Tune-Up	1/25	77-830	Channel Conversion	2/11-14	77-849	Channel Conversion	77-849	Channel Conversion	2/11-14
76-858		77-830	Channel Conversion	2/11-14	77-849	Channel Conversion	77-849	Channel Conversion	2/11-14
76-860		77-830	Channel Conversion	2/11-14	77-849	Channel Conversion	77-849	Channel Conversion	2/11-14
76-863		77-830	Channel Conversion	2/11-14	77-849	Channel Conversion	77-849	Channel Conversion	2/11-14
76-886		77-830	Channel Conversion	2/11-14	77-849	Channel Conversion	77-849	Channel Conversion	2/11-14
77-003(3001)		77-830	Channel Conversion	2/11-14	77-849	Channel Conversion	77-849	Channel Conversion	2/11-14
77-092		77-830	Channel Conversion	2/11-14	77-849	Channel Conversion	77-849	Channel Conversion	2/11-14
77-099		77-830	Channel Conversion	2/11-14	77-849	Channel Conversion	77-849	Channel Conversion	2/11-14
77-101B		77-830	Channel Conversion	2/11-14	77-849	Channel Conversion	77-849	Channel Conversion	2/11-14
77-101C		77-830	Channel Conversion	2/11-14	77-849	Channel Conversion	77-849	Channel Conversion	2/11-14
77-102(102M)		77-830	Channel Conversion	2/11-14	77-849	Channel Conversion	77-849	Channel Conversion	2/11-14
77-104XL		77-830	Channel Conversion	2/11-14	77-849	Channel Conversion	77-849	Channel Conversion	2/11-14
77-112		77-830	Channel Conversion	2/11-14	77-849	Channel Conversion	77-849	Channel Conversion	2/11-14
77-116		77-830	Channel Conversion	2/11-14	77-849	Channel Conversion	77-849	Channel Conversion	2/11-14
77-145		77-830	Channel Conversion	2/11-14	77-849	Channel Conversion	77-849	Channel Conversion	2/11-14
77-149		77-830	Channel Conversion	2/11-14	77-849	Channel Conversion	77-849	Channel Conversion	2/11-14
77-151(151M)		77-830	Channel Conversion	2/11-14	77-849	Channel Conversion	77-849	Channel Conversion	2/11-14
77-155		77-830	Channel Conversion	2/11-14	77-849	Channel Conversion	77-849	Channel Conversion	2/11-14
77-200 (200M)		77-830	Channel Conversion	2/11-14	77-849	Channel Conversion	77-849	Channel Conversion	2/11-14
77-202A		77-830	Channel Conversion	2/11-14	77-849	Channel Conversion	77-849	Channel Conversion	2/11-14
77-202B		77-830	Channel Conversion	2/11-14	77-849	Channel Conversion	77-849	Channel Conversion	2/11-14
77-202A		77-830	Channel Conversion	2/11-14	77-849	Channel Conversion	77-849	Channel Conversion	2/11-14
77-202B		77-830	Channel Conversion	2/11-14	77-849	Channel Conversion	77-849	Channel Conversion	2/11-14
77-250 & 77-250G (Power Max)		77-830	Channel Conversion	2/11-14	77-849	Channel Conversion	77-849	Channel Conversion	2/11-14
77-285		77-830	Channel Conversion	2/11-14	77-849	Channel Conversion	77-849	Channel Conversion	2/11-14
77-808		77-830	Channel Conversion	2/11-14	77-849	Channel Conversion	77-849	Channel Conversion	2/11-14
77-821		77-830	Channel Conversion	2/11-14	77-849	Channel Conversion	77-849	Channel Conversion	2/11-14
77-824		77-830	Channel Conversion	2/11-14	77-849	Channel Conversion	77-849	Channel Conversion	2/11-14
77-824B		77-830	Channel Conversion						

Master Index (For Volume 1 Thru Volume 7)

Tune-Up	1/29	PUMA 238		GRANT-DX		Power Modification	1/54
CBST-23 (Sidealk 23)		Tune-Up	1/30	Tune-Up	1/51	Repair Tip (Regulator Failure)	1/60
SIDETALK 1000B		PUMA 23C		Tune-Up	1/31	Super Side Conversion	3/14
SIDETALK 1000BC		Tune-Up	1/31	Variable Adjustments	4/50	Variable Adjustments	1/32
SIDETALK 1000M		PUSSYCAT 23		GRANT-XL		PC-3	1/62
SIDETALK CB-1023		SBMA SSB (Late Model)		Channel Conversion(Switch)	5/09	PC-3 (Emergency Radio)	
Tune-Up	1/29	SUPER LYNX		Channel Conversion(Rotary)	5/12	PC22	
PACER RADIOS		SUPER TIGER 40A		Clarifier Conversion	5/13	Tune-Up	1/46
Tune-Up	5/05	TIGER 238		Clarifier Conversion/Update	7/35	PC-33	
PACIFIC RADIOS		TIGER 23C		Tune-Up	5/05	Power Modification	1/59
160		TIGER 23D		Super-Side Conversion	5/14	Tune-Up	1/46
Variable Adjustments	1/65	Tune-Up	1/31	Super-Side Conversion/Update	7/36	Variable Adjustments	4/50
PAL RADIOS		TIGER 40		HONEST ABE		PC-33X	
COYE23		Channel Conversion	2/11-14	Channel Conversion	2/15-17	Tune-Up	1/46
ROADRUNNER 23		Tune-Up	1/31	Power Modification	1/54	PC-43	
Tune-Up	1/29	TIGER 40A		Super-Talk Installation	3/28	Tune-Up	1/46
PALOMAR RADIOS		Power Modification	1/53	Tune-Up	1/32	PC-55	
SSB-500		Variable Adjustments	3/36	HR-2510		Power Modification	1/59
Channel Conversion (MC145106)	5/20	TOMCAT 23B		Channel Modification	5/23	Tune-Up	1/46
Clarifier Modification	5/21	TOMCAT 23C		External Speaker Mod. Jack	3/29	Variable Adjustments	4/50
Tune-Up	1/30	Channel Conversion	2/11-14	Tune-Up	1/46	PC-55X	
Variable Adjustments	3/36	PIONEER RADIOS		HR-2510 (New release summer 95)		Tune-Up	1/46
21		GT-500	GT-6500	Tune-Up	7/05	PC-66 & PC66A	
49		GT-1000G		Channel Modification	5/24	Power Modification	1/58
Tune-Up	1/29	Variable Adjustments	1/31	RIT Modification	5/24	Super-Talk Installation	2/06
1200 (Export)		PRESIDENT / UNIDEN RADIOS		Tune-Up	5/05	Tune-Up	1/46
Tune-Up	1/29	ADAMS		JACKSON (Old Version)		Variable Adjustments	4/50
Variable Adjustments	1/63	Tune-Up	1/31	Variable Adjustments	1/32	PC-60X	
2400		ANDREW 12"		Variable Adjustments	1/64	Power Modification	7/38
Tune-Up	1/29	Power Modification	1/53	JACKSON (New Export Model PR-0A2C)		Tune-Up	5/05
Variable Adjustments	1/65	Super-Talk Installation	2/05	Variable Adjustments	1/32	PC-76XL	
2900		AR-7, AX-7		JAMES K	1/63	Power Modification	7/38
4100		Power Modification	1/53	Tune-Up	1/32	Tune-Up	5/05
Tune-Up	1/29	Tune-Up	1/31	JFK		PC-76XLW	
5000		Variable Adjustments	4/50	Tune-Up	1/32	Power Modification	7/05
Tune-Up	1/30	AR-14, AX-14		Variable Adjustments	1/63	Variable Adjustments	7/41
Variable Adjustments	1/65	Power Modification	1/58	JOHN D		PC-77	
PANASONIC RADIOS		Tune-Up	1/31	Channel Conversion	2/15-17	Power Modification	2/09
RJ-3050	RJ-3450	AR-44, AX-44		Power Modification	1/54	Tune-Up	1/46
RJ-3100	RJ-3600	Power Modification	1/58	Tune-Up	1/32	Variable Adjustments	4/50
RJ-3150	RJ-3600	Super-Talk Installation	2/06	LINCOLN		PC-122	
RJ-3200	RJ-3700	Tune-Up	1/31	External Speaker Mod. Jack	3/29	Power Modification	2/09
RJ-3250		Variable Adjustments	4/50	Repair Tip	2/32	Tune-Up	1/46
Tune-Up	1/30	AR-71, AX711		Tune-Up	1/32	PC-122XL	
CO-8591SEU		Power Modification	1/58	MADISON (858 PLL)		Power Modification	7/38
CR-81717EU		Super-Talk Installation	2/06	Channel Conversion#1	2/18, 19	Variable Adjustments	5/05
CR-84737EU		Tune-Up	1/31	Channel Conversion #2 (Rotary)	2/22	Variable Adjustments	7/41
CR-84747EU		Variable Adjustments	4/50	Channel Conversion #3	2/23	PC-244	
Tune-Up	1/30	Variable Adjustments	4/50	Clarifier Conversion	2/20	Power Modification	1/59
PARADYNAMICS RADIOS		AX4	AX-7	Power Modification	1/54	Tune-Up	1/46
PDC19		AX-11	AX-24	Power Supply Schematic & Mod.	5/29,30	Variable Adjustments	4/50
Tune-Up	5/05	AX-43		Repair Tip (Relay Buzzing)	1/60	PC-501XL	
Variable Adjustments	5/05	AX-52		Tune-Up	1/32	Tune-Up	7/05
PDC25		AX-55		Wobanding Procedure	2/20	Variable Adjustments	7/41
Tune-Up	5/05	Tune-Up	1/31	Variable Adjustments	1/65	PRO-500Q	
Variable Adjustments	5/05	CONVOY II		MADISON (8719 PLL)		Power Modification	1/58
PDC29		Power Modification	1/53	Channel Conversion(Switch)	2/24	Tune-Up	1/46
Tune-Up	5/05	Tune-Up	1/31	Clarifier Conversion	2/25	PC-501XL	
Variable Adjustments	5/05	Variable Adjustments	4/50	Clarifier Conversion/Update	3/25	Tune-Up	7/05
PEARSE-SIMPSON RADIOS		DWIGHT D (858 PLL)		Power Modification	1/53	Variable Adjustments	7/41
ALLEYCAT 23		Channel Conversion	2/15-17	Repair Tip (Regulator Failure)	1/60	PRO-510e	
BEARCAT 23C		Power Modification	1/54	Tune-Up	1/46	Tune-Up	1/46
BENGAL SSB		Tune-Up	1/31	Variable Adjustments	1/63	Variable Adjustments	4/51
BOBCAT 23B		DWIGHT D (1003002)		MCKINLEY (8719 PLL)		PRO-510XL	
BOBCAT 23D		Channel Conversion	2/15-17	Channel Conversion	2/27	Power Modification	1/58
BOBCAT 23E		Power Modification	1/54	Clarifier Conversion	2/20	Tune-Up	1/46
Tune-Up	1/30	Tune-Up	1/31	Power Modification	1/54	Variable Alignments	3/38
CHEETAH SSB		GRANT (858 PLL)		Variable Adjustments	1/32	PRO-520XL	
Tune-Up	1/30	Channel Conversion#1	2/18,19	MCKINLEY (Export)		Power Modification	1/58
Tune-Up (Correction)	3/05	Channel Conversion #2 (Rotary)	2/22	OLD HICKORY		Tune-Up	1/46
COUGAR 23		Channel Conversion #3	2/23	Tune-Up	1/32	Variable Adjustments	3/38
COUGAR 23B		Clarifier Conversion	3/25	P200		PRO-530L	
JAGUAR 40B		Power Modification	1/54	Power Modification	1/54	Tune-Up	1/46
LEOPARD B		Repair Tip (Relay Buzzing)	1/60	Tune-Up	1/32	Variable Adjustments	4/51
Tune-Up	1/30	Tune-Up	1/31	P210		PRO-535e	
LION 40		Misbanding Procedure	2/20	Tune-Up	1/32	Tune-Up	2/03
Channel Conversion	2/11-14	GRANT (8719 PLL)		P220 (Same as PC65)		Variable Adjustments	3/38
Tune-Up	1/30	Channel Conversion(Switch)	2/24	Power Modification	1/53	PRO-535e	
LYNX 23		Clarifier Conversion	2/25	Super-Talk Installation	2/06	Tune-Up	2/03
Tune-Up (Correction)	3/05	Clarifier Conversion/Update	3/25	Tune-Up	1/32	PRO-530L	
MARK II		Power Modification	1/53	P300		Tune-Up	3/05
Power Modification	1/53	Repair Tip (Regulator Failure)	1/60	Tune-Up	1/32	Variable Adjustments	3/38
Tune-Up	1/30	Tune-Up	1/46	P400 (8719 PLL)		Tune-Up	1/46
PANTHER SSB		GRANT (Export)		Channel Conversion	2/27	Variable Adjustments	3/38
		Channel conversion	2/28	Channel Conv. w 11 1125 Xtal	3/12		
		Clarifier Conversion	2/29	Clarifier Modification	2/27		

Master Index (For Volume 1 Thru Volume 7)

PRO-640s	Tune-Up	1/46	Tune-Up	Variable Adjustments	1/63	Tune-Up	1/35	Power Modification	2/08			
PRO-710e	Tune-Up	1/46	RCI-2970	Tune-Up	5/05	TRC-426	Power Modification	1/56	Tune-Up	1/35		
Variable Adjustments	4/51	RCI-2980	Channel Conversion	7/13	TRC-427	Variable Adjustments	3/36	TRC-468	Tune-Up	1/35		
PRO-810e	Alignment Procedure	4/32	Channel Chart	7/18	TRC-428	Power Modification	1/56	TRC-469	Power Modification	1/57		
Alignment Layout	4/34	Tune-Up	7/05	Variable Adjustments	7/40	Tune-Up	1/35	Super Talk Installation	3/27	Tune-Up	1/35	
Block Diagram & Flow Chart	5/31	RCI-2990	Channel Conversion	7/17	TRC-429	Variable Adjustments	3/36	TRC-470	Tune-Up	1/35		
Clarifier Modification	4/31	Tune-Up	7/05	Tune-Up	7/05	TRC-430	Variable Adjustments	3/36	TRC-471	Power Modification	1/57	
Power Supply Schematic	4/35	RCI-3000	Channel Conversion	7/17	TRC-431	Variable Adjustments	3/37	TRC-472	Tune-Up	1/35		
Tune-Up	1/46	Tune-Up	7/05	Tune-Up	7/05	TRC-432	Super-Talk Installation	5/27	TRC-473	Tune-Up	1/35	
Voltage Chart	5/32,33,34,35	ST-1000/HZAB18	Variable Adjustments	7/40	TRC-433	Channel Conversion	3/22,23	TRC-474	Power Modification	1/56		
Power Modification	1/59	Tune-Up	6/06	Tune-Up	6/06	TRC-434	Power Modification	1/56	Variable Adjustments	4/48		
Tune-Up	1/46	Variable Adjustments	6/35	Variable Adjustments	6/35	TRC-435	Tune-Up	1/35	TRC-473 (New Model)	Tune-Up	1/36	
Variable Adjustments	4/51	RAY JEFFERSON RADIOS		TRC-436	Tune-Up	1/35	TRC-437	Super-Talk Installation	5/27	TRC-474 (NEW MODEL)	Tune-Up	1/36
TEDDY R	Channel Conversion	2/15-17	CB-707	CB-845		TRC-438	Power Modification	1/56	TRC-439	Tune-Up	1/36	
Power Modification	1/54	CB-740	CB-905		1/33	TRC-440	Tune-Up	1/35	TRC-440	Variable Adjustments	3/37	
Tune-Up	1/32					TRC-441	Super-Talk Installation	5/27	TRC-441	Power Modification	1/56	
THOMAS J	Power Modification	1/55	REALISTIC RADIOS			TRC-442	Tune-Up	1/35	TRC-442	Tune-Up	1/35	
Power Modification	1/55	TRC-10	TRC-35C			TRC-443	Power Modification	1/56	TRC-443	Tune-Up	1/36	
Tune-Up	1/32	TRC-28B	TRC-46			TRC-444	Tune-Up	1/35	TRC-444	Variable Adjustments	3/37	
KEEP	Power Modification	1/55	TRC-23C	TRC-47		TRC-445	Tune-Up	1/35	TRC-445	Tune-Up	3/05	
Power Modification	1/55	TRC-24B	TRC-48			TRC-446	Tune-Up	1/35	TRC-446	Variable Adjustments	3/37	
Tune-Up	1/32	TRC-24C	TRC-49			TRC-447	Tune-Up	2/03	TRC-447	Tune-Up	1/36	
WASHINGTON (858 PLL)	Channel Conversion #1	2/18,19	TRC-39			TRC-448	Tune-Up	5/05	TRC-448	Variable Adjustments	5/05	
Channel Conversion #2 (Rotary)	2/22	TRC-30	TRC-30A		1/33	TRC-449	Channel Conversion	2/19	TRC-449	Channel Conversion Toggle Sw.	4/23	
Channel Conversion #3	2/23	Tune-Up	Tune-Up			TRC-450	Channel Conversion #1	2/19	TRC-450	Channel Chart	4/24	
Clarifier Conversion	2/20	TRC-180	TRC-180			TRC-451	Channel Conversion #2 (Rotary)	2/22	TRC-451	Clarifier Conversion	4/25	
Power Modification	1/55	TRC-52	TRC-190			TRC-452	Channel Conversion #3	2/23	TRC-452	Super Talk Installation	5/28	
Power Supply Schematic & Mod.	5/29,30	TRC-55	TRC-200			TRC-453	Clarifier Conversion	2/20	TRC-453	TRC-492	3/05	
Repair Tip (Relay Buzzing)	1/60	TRC-56	TRC-204			TRC-454	Variable Adjustments	3/37	TRC-454	Variable Adjustments	4/48	
Tune-Up	1/32	TRC-57	TRC-205			TRC-455	Variable Adjustments	5/46	TRC-455	Power Modification	1/56	
Widebanding Procedure	2/20	TRC-61	TRC-206			TRC-456	Power Modification	1/56	TRC-456	Tune-Up	1/35	
WASHINGTON (8719 PLL)	Channel Conversion	2/27	TRC-67	TRC-208		TRC-457	Tune-Up	1/35	TRC-457	Tune-Up	1/35	
Channel Conv. w/11.1125 Mhz.	3/12	TRC-68	TRC-209		1/34	TRC-458	Variable Adjustments	5/46	TRC-458	Channel Conversion #1	2/19	
Clarifier Conversion	2/27	TRC-210	TRC-215			TRC-459	Channel Conversion #1	2/19	TRC-459	Channel Conversion #2 (Rotary)	2/22	
Power Modification	1/54	TRC-211	TRC-216			TRC-460	Channel Conversion #2 (Rotary)	2/22	TRC-460	Channel Conversion #3	2/23	
Power Modification	1/54	TRC-212	TRC-217			TRC-461	Clarifier Conversion	2/20	TRC-461	Clarifier Conversion	2/20	
Super Side Conversion	3/14	TRC-213	TRC-218		1/34	TRC-462	Repair Tip (Relay Buzzing)	1/60	TRC-462	Power Modification	1/56	
Super Talk Installation	3/28	TRC-410	Tune-Up			TRC-463	Tune-Up	1/35	TRC-463	Variable Adjustments	3/36	
Tune-Up	1/47	TRC-411	Tune-Up			TRC-464	Widebanding Procedure	2/20	TRC-464	Power Modification	1/56	
Variable Adjustments	1/62	TRC-412	Tune-Up		1/34	TRC-465	Variable Adjustments	4/48	TRC-465	Tune-Up	1/35	
ZACHARY T (858 PLL)	Channel Conversion	2/15-17	TRC-413	Tune-Up	1/34	TRC-466	TRC-414	Power Modification	1/56	TRC-466	Variable Adjustments	3/36
Channel Conversion	2/15-17	TRC-414	Tune-Up	1/34	4/48	TRC-467	TRC-414	Power Modification	1/56	TRC-467	Variable Adjustments	3/36
Power Modification	1/54	TRC-415	Variable Adjustments	1/34	4/48	TRC-468	TRC-415	Power Modification	1/55	TRC-468	Power Modification	1/55
Tune-Up	1/32	TRC-416	Power Modification	1/55	1/34	TRC-469	TRC-416	Tune-Up	1/35	TRC-469	Tune-Up	1/35
ZACHARY T (New Version)	Power Modification	1/59	TRC-417	Tune-Up	1/34	TRC-470	TRC-417	Variable Adjustments	3/36	TRC-470	Power Modification	1/55
Power Modification	1/59	TRC-418	Power Modification	1/55	1/34	TRC-471	TRC-418	Power Modification	1/55	TRC-471	Power Modification	1/55
Tune-Up	1/47	TRC-419	Tune-Up	1/34	1/34	TRC-472	TRC-419	Tune-Up	1/35	TRC-472	Tune-Up	1/35
PYRAMID RADIOS	TRC-420	Power Modification	1/55	TRC-420	Power Modification	1/55	TRC-420	Power Modification	1/55	TRC-420	Power Modification	1/55
CB-22	Tune-Up	1/32	TRC-415	Tune-Up	1/34	TRC-421	TRC-421	Power Modification	1/55	TRC-421	Power Modification	1/55
Tune-Up	1/32	TRC-422	TRC-420A	Tune-Up	1/34	TRC-422	TRC-422	Power Modification	1/55	TRC-422	Power Modification	1/55
CB-22 (NEW MODEL)	Tune-Up	1/32	Tune-Up	1/34	1/34	TRC-423	TRC-423	Power Modification	1/55	TRC-423	Power Modification	1/55
Tune-Up	1/32	TRC-423	TRC-420A	Tune-Up	1/34	TRC-424	TRC-424	Power Modification	1/56	TRC-424	Power Modification	1/56
Variable Adjustments	3/36	TRC-424	TRC-421	Tune-Up	1/34	TRC-425	TRC-425	Power Modification	1/56	TRC-425	Power Modification	1/56
CB-24	Tune-Up	1/32	TRC-425	Tune-Up	1/34	TRC-426	TRC-426	Power Modification	1/56	TRC-426	Power Modification	1/56
Tune-Up	1/32	TRC-426	TRC-422	Tune-Up	1/34	TRC-427	TRC-427	Power Modification	1/56	TRC-427	Power Modification	1/56
Variable Adjustments	3/36	TRC-427	TRC-423	Tune-Up	1/35	TRC-428	TRC-428	Power Modification	1/56	TRC-428	Power Modification	1/56
CB-25	Tune-Up	1/32	TRC-428	Tune-Up	1/35	TRC-429	TRC-429	Power Modification	1/56	TRC-429	Power Modification	1/56
Variable Adjustments	3/36	TRC-429	TRC-424	Tune-Up	1/35	TRC-430	TRC-430	Power Modification	1/56	TRC-430	Power Modification	1/56
Tune-Up	1/32	TRC-430	TRC-421	Tune-Up	1/34	TRC-431	TRC-431	Power Modification	1/56	TRC-431	Power Modification	1/56
CB-28	Variable Adjustments	3/36	TRC-431	Tune-Up	1/34	TRC-432	TRC-432	Power Modification	1/56	TRC-432	Power Modification	1/56
Tune-Up	1/32	TRC-432	TRC-422	Tune-Up	1/34	TRC-433	TRC-433	Power Modification	1/56	TRC-433	Power Modification	1/56
Variable Adjustments	3/36	TRC-433	TRC-423	Tune-Up	1/34	TRC-434	TRC-434	Power Modification	1/56	TRC-434	Power Modification	1/56
CB-29	Tune-Up	1/32	TRC-434	Tune-Up	1/34	TRC-435	TRC-435	Power Modification	1/56	TRC-435	Power Modification	1/56
Variable Adjustments	3/36	TRC-435	TRC-424	Tune-Up	1/34	TRC-436	TRC-436	Power Modification	1/56	TRC-436	Power Modification	1/56
Tune-Up	1/32	TRC-436	TRC-421	Tune-Up	1/34	TRC-437	TRC-437	Power Modification	1/56	TRC-437	Power Modification	1/56
CB-38	Power Modification	1/55	TRC-437	Tune-Up	1/34	TRC-438	TRC-438	Power Modification	1/56	TRC-438	Power Modification	1/56
Variable Adjustments	3/36	TRC-438	TRC-425	Tune-Up	1/34	TRC-439	TRC-439	Power Modification	1/56	TRC-439	Power Modification	1/56
Tune-Up	1/32	TRC-439	TRC-422	Tune-Up	1/34	TRC-440	TRC-440	Power Modification	1/56	TRC-440	Power Modification	1/56
Variable Adjustments	3/36	TRC-440	TRC-423	Tune-Up	1/34	TRC-441	TRC-441	Power Modification	1/56	TRC-441	Power Modification	1/56
CB-39	Tune-Up	1/32	TRC-441	Tune-Up	1/34	TRC-442	TRC-442	Power Modification	1/56	TRC-442	Power Modification	1/56
Variable Adjustments	3/36	TRC-442	TRC-426	Tune-Up	1/34	TRC-443	TRC-443	Power Modification	1/56	TRC-443	Power Modification	1/56
Tune-Up	1/32	TRC-443	TRC-427	Tune-Up	1/34	TRC-444	TRC-444	Power Modification	1/56	TRC-444	Power Modification	1/56
CB-39	Power Modification	1/55	TRC-444	Tune-Up	1/34	TRC-445	TRC-445	Power Modification	1/56	TRC-445	Power Modification	1/56
Variable Adjustments	3/36	TRC-445	TRC-427	Tune-Up	1/34	TRC-446	TRC-446	Power Modification	1/56	TRC-446	Power Modification	1/56
Tune-Up	1/32	TRC-446	TRC-428	Tune-Up	1/34	TRC-447	TRC-447	Power Modification	1/56	TRC-447	Power Modification	1/56
CB-39	Power Modification	1/55	TRC-447	Tune-Up	1/34	TRC-448	TRC-448	Power Modification	1/56	TRC-448	Power Modification	1/56
Variable Adjustments	3/36	TRC-448	TRC-428	Tune-Up	1/34	TRC-449	TRC-449	Power Modification	1/56	TRC-449	Power Modification	1/56
Tune-Up	1/32	TRC-449	TRC-429	Tune-Up	1/34	TRC-450	TRC-450	Power Modification	1/56	TRC-450	Power Modification	1/56
GTL-148	Power Modification	1/55	TRC-450	Tune-Up	1/34	TRC-451	TRC-451	Power Modification	1/56	TRC-451	Power Modification	1/56
Tune-Up	1/32	TRC-451	TRC-429	Tune-Up	1/34	TRC-452	TRC-452	Power Modification	1/56	TRC-452	Power Modification	1/56
Tune-Up	1/32	TRC-452	TRC-430	Tune-Up	1/34	TRC-453	TRC-453	Power Modification	1/56	TRC-453	Power Modification	1/56
1300	Power Modification	1/55	TRC-453	Tune-Up	1/34	TRC-454	TRC-454	Power Modification	1/56	TRC-454	Power Modification	1/56
Tune-Up	1/32	TRC-454	TRC-431	Tune-Up	1/34	TRC-455	TRC-455	Power Modification	1/56	TRC-455	Power Modification	1/56
Tune-Up	1/32	TRC-455	TRC-432	Tune-Up	1/34	TRC-456	TRC-456	Power Modification	1/56	TRC-456	Power Modification	1/56
QUESTAR RADIOS	Power Modification	1/55	TRC-456	Tune-Up	1/34	TRC-457	TRC-457	Power Modification	1/56	TRC-457	Power Modification	1/56
MARK-I	Variable Adjustments	3/36	TRC-457	Tune-Up	1/34	TRC-458	TRC-458	Power Modification	1/56	TRC-458	Power Modification	1/56
Tune-Up	1/32	TRC-458	TRC-433	Tune-Up	1/34	TRC-459	TRC-459	Power Modification	1/56	TRC-459	Power Modification	1/56
RANGER RADIOS	Power Modification	1/55	TRC-459	Tune-Up	1/34	TRC-460	TRC-460	Power Modification	1/56	TRC-460	Power Modification	1/56
RCI-2900	Power Modification	1/55	TRC-460	Tune-Up	1/34	TRC-461	TRC-461	Power Modification	1/56	TRC-461	Power Modification	1/56
Tune-Up	1/33	TRC-461	TRC-434	Tune-Up	1/34	TRC-462	TRC-462	Power Modification	1/56	TRC-462	Power Modification	1/56
RCI-2950	Tune-Up	1/33	TRC-462	Tune-Up	1/34	TRC-463	TRC-463	Power Modification	1/56	TRC-463	Power Modification	1/56
Channel Conversion	4/42	TRC-463	TRC-435	Tune-Up	1/34	TRC-464	TRC-464	Power Modification	1/56	TRC-464	Power Modification	1/56
Clarifier Modification	4/42	TRC-464	TRC-436	Tune-Up	1/34	TRC-465	TRC-465	Power Modification	1/56	TRC-465	Power Modification	1/56
Improvement Modifications	4/43	TRC-465	TRC-437	Tune-Up	1/34	TRC-466	TRC-					

Master Index (For Volume 1 Thru Volume 7)

ROBYN RADIOS

AM-500D	
Channel Conversion	2/15
Power Modification	1/57
Tune-Up	1/36
DC-30	
Tune-Up	1/36
DC-190A	T-240D
GT-410D	TR-123C
GT-VIIB	TR-123D
K-123	
LB-29A	LB-120
Tune-Up	1/37
SB-50SD	
Tune-Up	1/37
SB-610D	
Alignment Procedure (See 520-0)	3/32
Channel Conversion#1	2/18
Channel Conversion #2 (Rotary)	2/22
Channel Conversion #3	2/23
Clarifier Conversion	2/20
Power Modification	1/57
Repair Tip (Relay Buzzing)	1/60
Tune-Up	1/37
Widening Procedure	2/20
SB-520D	
Alignment Procedure	3/32
Channel Conversion#1	2/18
Channel Conversion #2 (Rotary)	2/22
Channel Conversion #3	2/23
Clarifier Conversion	2/20
Power Modification	1/57
Power Supply Schematic & Mod.	5/29, 2/30
Repair Tip (Relay Buzzing)	1/60
Tune-Up	1/37
Widening Procedure	2/20
SB-540	
Tune-Up	1/37
SX-401	WW-110
SX-401	007-140
WW-23A	440
WW-23	
Tune-Up	1/37
ROYCE RADIOS	
1-580	1-602A
1-582	1-605A
1-601 (PII Version)	1-606
1-602	1-610
Tune-Up	1/37
1-611	
1-612	
Tune-Up	1/37
1-613	
Tune-Up	1/37
Variable Adjustments	5/47
1-617	
Tune-Up	1/37
1-620	
1-621	
1-624	
Tune-Up	1/37
1-625	
Tune-Up	1/38
1-630	1-651
1-631	1-653
1-632	1-655
1-635	1-658
1-639	1-659
1-640	1-662
1-641	1-673
1-642	1-675
1-648	1-678
1-650	1-680
Tune-Up	1/38
603	
Tune-Up	1/38
604	
Tune-Up	1/38
607	
Tune-Up	1/38
Variable Adjustments	4/49
608	
609	
611	
613	
619	
639	
Tune-Up	1/38

RYSTAL RADIOS

CB-523	
CBR-1700	
CBR-1800	
Tune-Up	1/38
SAGA RADIOS	
2530	
Tune-Up	1/39
SAM RADIOS	
SAM 2000	
Tune-Up	1/39
SANKYO RADIOS	
SCS-555	
Tune-Up	1/39
SANYO RADIOS	
TA-2000	
TA-4000	
TA-6000	
Tune-Up	1/39
SBE RADIOS	
LCB-8	
Tune-Up	1/39
LCM-8	
Tune-Up	1/39
Variable Adjustments	4/49
LCM-8P	
LCMS	
Tune-Up	1/39
5C9	12CB
14CB	16CB (Console II)
21CB (Cortez)	22CB (Catalina II)
Tune-Up	1/39
23CB (Cari II)	
26CB (Formula D)	
27CB (Formula 40)	
27CB (A)	
29CB (Maibu)	
Tune-Up	1/39
30CB (Trinidad II)	
32CB (Touchcom)	
34CB (Brute)	
39CB (Sidebender V)	
40CB	
41CB (Aspen)	
Tune-Up	1/39
42CB (Cortez)	
43CB (TouchCom 40)	
44CB (Maibu 40)	
45CB (Trinidad III)	
47CB (Stowaway)	
49CB (Tahoe)	
54CB (Key/Com 1000)	
Tune-Up	1/40
TRINIDAD 23 CH.	
CONSOLE V	
CONSOLE VI	
Tune-Up	1/40
SEARS	
242-38160700	
37D-38050700	
Tune-Up	1/40
592-38207000	
Channel Conversion#1	2/30
Tune-Up	1/40
592-38220700	
Tune-Up	2/03
663-38009000	
Power Modification	2/08
Tune-Up	1/40
663-38060500	
Tune-Up	2/03
Power Modification	2/09
663-38030090	
Tune-Up	1/40
663-38020800	
Tune-Up	1/40
663-38070700	
Channel Conversion	2/15
Tune-Up	1/40
7531	
Tune-Up	1/40
934-36710500	
934-36740500	
934-36741600	

934-36770500	
934-36771500	
934-36772600	
Tune-Up	1/40
934-38060700	
934-38061700	
Power Modification (82700)	2/09
Tune-Up	1/40
934-38062700	
Power Modification (62700)	2/09
Tune-Up	1/40
934-38060700	
Power Modification (62700)	2/09
Tune-Up	1/40
Variable Adjustments	3/37
934-38061700	
Tune-Up	1/40
934-38110700	
Tune-Up	1/40
Variable Adjustments	5/47
934-38120700	
934-38207000	
Tune-Up	1/40
934-38270700 Base/Mobile	
Channel Conversion Rotary Sw.	4/28
Channel Chart	4/27
Clarifier Modification	4/28
Power Supply Schematic	4/29
Tune-Up	1/40
934-38310700	
Tune-Up	1/40
Variable Adjustments	3/37
SHAKESPEARE RADIOS	
GBS-240	
GBS-1500	
GBS-2000	
GBS-2500	
Tune-Up	1/41
SHARK RADIOS	
SHARK 23	
Tune-Up	1/41
W-705	
Tune-Up	4/05
Variable Adjustments	4/05
SHARP RADIOS	
CB-500UB	
CB-700	
CB-750A	
CB-800	
CB-850A	
CB-21170	
CB-2260	
Tune-Up	1/41
CB-2460	
Tune-Up	1/41
Tune-Up	3/05
CB-4370	
CB-4470	
CB-4570	
CB-5470	
Tune-Up	1/41
SILTRONIX RADIOS	
APACHE (AM-1)	
CHEROKEE	
MONARK (AM-2)	
SSB-23	
SSB-23A (Albatross)	
Tune-Up	1/41
SOMMERKAMP RADIOS	
TS-2000DX	
Tune-Up	2/03
SOUND CREATION RADIOS	
SCB-500X	
Tune-Up	5/05
Variable Adjustments	5/05
SPARKMATIC RADIOS	
CB-1140	
CB-1040	RA-400
CB-1123	SBR-1CBM
Tune-Up	1/41
STAG RADIOS	
Stag 357	
Tune-Up	1/42

STANDARD COMMUNICATIONS RADIOS

Horizon 28-23 CH.	
Horizon 28-40 CH.	
Tune-Up	1/42
STARFIRE RADIOS	
STARFIRE DX	
Variable Adjustments	1/41
Variable Adjustments	1/65
STEREOSONIC RADIOS	
2300	
2301	
2302	
2350	
2355	
2360	
Tune-Up	1/42
SUPERSCOPE (AIR COMMAND) RADIOS	
CB-140	
CB-340	
CB-640	
CB8-1040	
CBR-40 AM/FM/CB	
Tune-Up	1/42
SUPERSTAR RADIOS	
95	
Tune-Up	1/42
Variable Adjustments	1/62
120 (Old Model)	
Tune-Up	1/42
Variable Adjustments	5/56
120 (New Model Similar to Tristar 120)	
Tune-Up	4/05
121	
10 kHz Jump Modification	4/20
Tune-Up	2/03
Power Modification	2/09
Variable Adjustments	2/33
121 (EPT 1201122 Board)	
Switch Channel Conversion	6/27
Rotary Channel Conversion	6/28
Channel Conversion Chart	6/29
+10 kHz Jump Modification	6/30
Tune-Up	6/08
Variable Adjustments	6/35
360 (Early Model)	
Tune-Up	1/42
300FM (P9010 Chassis Board)	
10 kHz Jump Modification	4/20
Tune-Up	1/42
Tune-Up	8/06
Variable Adjustments	1/64
505F	
Tune-Up	4/05
Variable Adjustments	4/05
1700	
Tune-Up	1/42
1700B	
Power Modification	1/57
Tune-Up	1/42
Variable Adjustments	1/63
1700S	
Power Modification	1/57
Tune-Up	1/42
Variable Adjustments	1/63
2000	
Tune-Up	1/42
Variable Adjustments	1/66
2200	
Tune-Up	1/42
Variable Adjustments	1/65
3600	
Power Modification	1/57
Tune-Up	1/42
Tune-Up	6/06
3900	
10 kHz Jump Modification	4/21
Channel Conversion	5/18
Clarifier Modification	5/16
Power Modification	1/57
Stock Clarifier Schematic	5/15
Super-Side Modification	5/17
Supertalk Installation	4/22
Tune-Up	1/42
Tune-Up	6/06
3900Q	
Tune-Up	7/05

Master Index (For Volume 1 Thru Volume 7)

2017

GR	Tune-Up..... 3/05	TITAN T	Channel Conversion..... 2/15-17	848	Tune-Up..... 1/45	UTAC RADIOS	
	Variable Adjustments..... 3/37		Tune-Up..... 1/43		Variable Adjustments..... 1/65	MICRO-MINI 23	
	JA (EPT 00JA10Z Board)	TEK RADIOS		TRS CHALLENGER RADIOS		STUDIO 4000	1/47
	Tune-Up..... 6/06	HR-3950		460		SUPER TINY 23	
	Variable Adjustments..... 6/35	Tune-Up..... 3/05		600	Tune-Up..... 1/45	TR-18M	
LBJ	Power Modification..... 2/09	Variable Adjustments..... 3/38		Tune-Up (Correction)..... 3/05		TRX-30	
	Tune-Up..... 2/03	TENNA RADIOS		730		TRX-400	
	Variable Adjustments..... 2/33	A5902		Tune-Up..... 1/45		TRX-500	
Tek-505D	Alignment Layout..... 4/14	10901	Tune-Up..... 1/44	Variable Adjustments..... 6/35		TRX-2000	
	Channel Conv. Toggle Sw..... 4/11	Tune-Up..... 1/44		1200	Tune-Up..... 1/45	Tune-Up (All the Above)..... 1/47	
	Channel Conv. Rotary Sw..... 4/12	Variable Adjustments..... 5/47		Tune-Up..... 1/45		VECTOR RADIOS	
	Channel Chart..... 4/13	10902		Variable Adjustments..... 3/38		770	
	Tune-Up..... 4/05	11302 (AM/FM/CB)	Tune-Up..... 1/44	1400	Tune-Up..... 1/45	790	
	Variable Adjustments..... 4/05	TEXAS STAR RADIOS		TRUETONE RADIOS		VECTOR IV	
	Voltage Chart..... 4/15	2100		CYJ4732A-77		VECTOR VI	
	Tek-505D	Power Modification..... 1/58		Tune-Up..... 1/45		VECTOR VII	
	Tune-Up..... 4/05	Tune-Up..... 1/44		CYJ4832A-87		VECTOR IX	
	Variable Adjustments..... 4/05	THUNDER RADIOS		Channel Conversion..... 2/11-14		VECTOR X	
SURVEYOR RADIOS		2000		Tune-Up..... 1/45		Tune-Up (All the Above)..... 1/47	
1500	2600	Tune-Up..... 1/44		CYJ4837A-87		WARDS RADIOS	
2100	2610	Variable Adjustments..... 1/65		Channel Conversion..... 2/11-14		GEN-680A	
2300	2620	TRAM RADIOS		Tune-Up..... 1/45		Tune-Up..... 1/48	
2500	2630	D12		CYJ4862A-87		GEN-695A	
Tune-Up..... 1/43		Tune-Up..... 1/44		Channel Conversion..... 2/11-14		Tune-Up..... 1/48	
TEABERRY RADIOS		D42		Tune-Up..... 1/45		Tune-Up (Correction for Old Volt)..... 3/05	
BIG T		Channel Conversion..... 3/20		Variable Adjustments..... 5/47		GEN-702A	
FIVE by FIVE (Early)	FIVE by FIVE (Late)	Tune-Up..... 1/44		CYJ4837A-87		GEN-716A	
Tune-Up..... 1/43	Tune-Up..... 1/43	D54		Tune-Up..... 1/45		Tune-Up..... 1/48	
MIGHTY T		Channel Conversion..... 3/20		CYJ4862A-87		GEN-719A	
MODEL T		Tune-Up..... 1/44		Channel Conversion..... 2/11-14		GEN-730A	
Tune-Up..... 1/43		D80		Tune-Up..... 1/45		GEN-774A	
RACER T (23 CH)		Channel Conversion..... 3/18		DC4530		GEN-775A	
RACER T (40 CH)		Tune-Up..... 1/44		DC4672		GEN-828A	
Tune-Up..... 1/43		D80		Tune-Up..... 1/45		Tune-Up..... 1/48	
STALKER 3		Channel Conversion..... 3/18		MCC4370A-57		WELLS RADIOS	
STALKER I		Tune-Up..... 1/44		MCC4434A-57		W-705	
STALKER II		D201		MCC4434A-67		Tune-Up..... 1/48	
Tune-Up..... 1/43		Tune-Up..... 1/44		MCC4434B-67		WESTPOINT RADIOS	
STALKER IV		D300		MCC4532A-47		CB-9000	
Tune-Up..... 1/43		Channel Conversion Toggle Sw..... 4/23		MCC4630A-67		Tune-Up..... 1/48	
Variable Adjustments..... 4/49		Channel Chart..... 4/24		MCC4635A-67		WHISTLER RADIOS	
STALKER V		Clarifier Conversion..... 4/25		MCC4724A-77		700	
STALKER VIII		Tune-Up..... 1/44		MCC4726A-67		Tune-Up..... 2/03	
Tune-Up..... 1/43		DIAMOND 40		MCC4760A-67		Tune-Up..... 1/48	
STALKER IX		DIAMOND 60		MCC4770		XTAL RADIOS	
Channel Conv (See Cobra140GTL) 2/27		Tune-Up..... 1/44		Tune-Up..... 1/45		XCB-4	
Clarifier Mod. (See Cobra140GTL) 2/27		TITAN II		MIC4350A-37		XCB-5	
Tune-Up..... 1/43		TITAN IV		MIC4434A-67		XCB-6	
Variable Adjustments..... 4/49		XL		MIC4622A-67		XCB-7	
STALKER IX (Export)		XL-5		MIC4726A-67		XCB-11	
Power Modification..... 1/58		Tune-Up..... 1/44		MIC4730A-67		XCB-12	
Tune-Up..... 1/43		TRI MAX RADIOS		MIC4731A-67		Tune-Up (All the Above)..... 1/48	
STALKER XV		220		MIC4733A-67		XCB-71	
Channel Conv (See Cobra142GTL) 2/27		Tune-Up..... 6/06		MIC4739A-67		Tune-Up..... 1/48	
Clarifier Mod. (See Cobra 142GTL) 2/27		Variable Adjustments..... 6/35		Tune-Up..... 1/46		Variable Adjustments..... 4/15	
Channel Conv. w 11.1125 Xtal..... 3/12		TRISTAR RADIOS		UNIDEN RADIOS		XCB-23A	
Super Slide Conversion..... 3/14		120		(See PRESIDENT / UNIDEN		900-25	
Tune-Up..... 1/43		Power Modification..... 1/58		CB-40		XCB-880	
Variable Adjustments..... 3/38		Tune-Up..... 1/44		Tune-Up..... 1/46		XSSB-4	
STALKER XX		240 (Old Model)		Variable Alignment..... 4/51		XSSB-10	
Tune-Up..... 1/43		Tune-Up..... 1/44		CB-50		Tune-Up (All the Above)..... 1/48	
Variable Adjustments..... 4/49		Variable Adjustments..... 4/49		Tune-Up..... 1/46		YOSAN RADIOS	
STALKER XX (Export)		240 (New Model)		RV-40		JC-2204	
Tune-Up..... 1/43		Power Modification..... 1/58		Tune-Up..... 1/46		Channel Conversion..... 6/24	
T		Tune-Up..... 1/44		Variable Alignment..... 4/51		Channel Conversion Chart..... 6/25	
Tune-Up..... 1/43		240 (New Model)		Tune-Up..... 1/46		Tune-Up..... 6/06	
T-BAR		Power Modification..... 1/58		UNIMETRICS RADIOS		Variable Adjustments..... 6/35	
Channel Conversion..... 2/15-17		Tune-Up..... 1/44		DOLPHINE		ZODIAC RADIOS	
Power Modification..... 1/58		727		MAKO-I		M-5023	
Super-Talk Installation..... 3/28		Variable Adjustments..... 1/62		MAKO-II		M-5026	
Tune-Up..... 1/43		747		PURPOSE I		Tune-Up..... 1/48	
T CHARLIE (40 CH)		Tune-Up..... 1/44		SEA-HORSE I			
Tune-Up..... 1/43		Variable Adjustments..... 1/64		STINGRAY II			
T COMMAND		777		Tune-Up (All the Above)..... 1/47			
Channel Conversion..... 2/15-17		Tune-Up..... 1/44		USACO RADIOS			
Power Modification..... 1/58		Variable Adjustments..... 1/65		USOOCB			
Tune-Up..... 1/43		797		Tune-Up..... 3/05			
T CONTROL		Tune-Up..... 1/44					
Tune-Up..... 1/43		Variable Adjustments..... 1/65					
T DISPATCH							
Channel Conversion..... 2/15-17							
Tune-Up..... 1/43							
T SCOUT							
Tune-Up..... 1/43							
TELE T							
Tune-Up..... 1/43							